

Section VI

Other Natural Fibres





CONTENTS

SUMMARY – OTHER NATURAL FIBRES	398
6.1. NATURAL FIBRES	404
OVERVIEW	404
VARIOUS NATURAL FIBRES	405
ECONOMIC IMPORTANCE OF NATURAL FIBRES	408
NEED FOR A FIBRE POLICY	409
6.2. PRESENT STATUS OF OTHER NATURAL FIBRES	411
BANANA FIBRE	411
PALM LEAF	411
SISAL	411
INDUSTRIAL HEMP	412
FLAX	412
RAMIE	412
KORAI GRASS	412
SCREW PINE	413
WATER HYACINTH	413
PINEAPPLE FIBRE	414
6.3. POTENTIAL FIBRES	415
INDUSTRIAL HEMP	415
FLAX FIBRE	420
CHINA- BRIEF PROFILE OF HEMP AND FLAX FIBRES	428
BANANA FIBRE	430
PHILIPPINES - BRIEF PROFILE OF ABACA FIBRE	438
SISAL FIBRE	440
CASE STUDY – SISAL INDUSTRY IN KENYA	445
PINEAPPLE FIBRE	446
6.4. RECOMMENDATIONS OF THE SUB-GROUP FOR OTHER NATURAL FIBRES	453



SELECTION OF FIVE KEY FIBRES FOR DEVELOPMENT	453
RECOMMENDATION FOR FURTHER STUDY	454
CENSUS ON OTHER NATURAL FIBRES	454
RECOMMENDATIONS/POLICY INTERVENTIONS FOR THE SELECTED FIVE FIBRES	455
PROPOSING A 'FOCUS FIBRE FOCUS STATE' APPROACH	455
OTHER INTERVENTIONS FOR DEVELOPMENT OF GROUP I & II FIBRES	458
INTERMEDIATE STRATEGY (FOR 5 YEARS)	460
LONG TERM STRATEGY	462
PROSPECTS/POTENTIAL FOR THE IDENTIFIED FIVE FIBRES	462
COMPOSITION OF THE SUB GROUP ON OTHER NATURAL FIBRES	464

SUMMARY – OTHER NATURAL FIBRES

- I. Natural fibres can be defined as bio-based fibres or fibres from vegetable and animal origin. Based on their origin, natural fibres can also be classified as cellulosic (from plants) and protein (from animals). Excluded here are mineral fibres such as asbestos that occur naturally but are not bio-based. Other natural fibres as defined for this policy are of plant origin, cellulosic and renewable. These other natural fibres are produced in considerably smaller volumes compared to cotton, the largest natural fibre (average 25 million tonnes per year), and are also much lower than production of wool and jute (2-3 million tonnes). Trade markets and exports of natural fibres such as sisal and henequen, jute, kenaf, flax and hemp have seen a decline in the past decades, which is often attributed to the introduction of cheaper synthetic substitutes. The recent global economic slowdown has adversely affected the demand for other natural fibres.
- II. Globally, the natural fibres industry provides employment to millions of people, largely small scale (marginal) farmers and processors. Natural fibres are more environment friendly than synthetic fibres both in terms of production and their disposal. Natural fibres are completely bio-degradable. Natural fibre can thus play a key role in the emerging “green” economy.
- III. India has a presence of a number of other natural fibres however the same have not been fully commercially exploited. India does not have a significant presence in other natural fibres, though ramie, flax, linen are used by Indian textile industry. Fibres such as agave (sisal), banana and pineapple fibres have huge potential.
- IV. The major plant based - other natural fibres includes, banana fibre, pineapple fibre, palm leaf, sisal, hemp, flax, ramie, bamboo, korai grass, screw pine, water hyacinth.
- V. **Banana fibre:** India is the world’s largest producer of banana; however only 10% of the banana waste (Pseudo stems) is used for extracting the fibre, rest is wasted. Presently, waste banana stems pose problem of disposal and are available almost free of cost in Central and South Gujarat. In India, banana fibre is primarily extracted manually, which has high labor costs and the yield is also low, resulting in irregular supply, leading to higher prices of banana fibres. In recent past India has developed ‘Banana Fibre Separator Machine’, which produces silk grade fibre, which can be used by handicrafts and textile industries.
- VI. Application of banana fibre for manufacturing textiles is a new concept in India. Banana fibre can be easily blended with cotton or other synthetic fibres to produce blended fabric and textiles. Currently, it is mainly used by cottage industry in Southern India. Banana fibre has the potential to partially replace the consumption of cotton and jute fibre in India. Banana fibre also finds use in high quality security/



currency paper, packing cloth for agriculture produce, ships towing ropes, wet drilling cables and others

- VII. **Palm leaf fibre:** Palm leaves are a major source of fibres and palm leaf fibre is used to make ropes, hats, brushes, fish nets, brooms, amongst others. In India it is cultivated as a windbreak on the plains in India. Palm fibre is being exported to US, UK, Belgium, Philippines, Japan, Germany, Australia and Netherlands by the Tamil Nadu State Palmgur and Fibre Marketing Cooperative Federation and exporters from Thuthukudi in Tamil Nadu.
- VIII. **Sisal:** Sisal industry in India is largely unorganized. Sisal is mainly grown in arid and semi-arid regions of Andhra Pradesh, Bihar, Orissa, Karnataka, Maharashtra and West Bengal. A number of programmes undertaken by government and government agencies (different states) have led to the cultivation of sisal. India is the 2nd largest importer and 5th largest exporter of sisal in the world. Sisal cultivation, fibre extraction and product making is a labor intensive process, with use of very low level of technology. Some of the problems associated with sisal are the long time taken for cultivation, low pace of introduction of new products, inadequate efforts for creating awareness of the fibre and of products made from it. Also, the process used to extract sisal has witnessed little change over the years.
- IX. Brazil, China, Tanzania and Kenya are the major producers of sisal in the world. Brazil, Kenya, Tanzania and Madagascar are the major exporters of sisal fibre in the world. China dominates the market for imports of sisal fibre currently.
- X. Sisal fibre can be used as a replacement for silk fibre. Sisal fibre has been traditionally used to make twines and ropes, due to its various strengths. However, in recent times it is being used for making specialty paper, filters, geotextiles, mattresses, carpets and wall coverings and as reinforcement in plastic composite materials and furniture. Use of sisal for different applications tends to vary according to its grade. In addition, the by-products from sisal extraction can be used in bio-gas, pharmaceutical ingredients and building materials.
- XI. **Hemp:** Hemp is primarily cultivated only in some districts in Uttarakhand, Kashmir and Travancore (Kerala). Currently, India is not strongly present in the map of hemp producing countries. The limited cultivation in selected parts of the country is mainly due to requirement of low soil temperature at the time of planting. There is an urgent need for raw material assessment and skill development in hemp producing regions.
- XII. Hemp fibre is a good conductor of heat. It dyes well, resists mildew, obstructs ultra violet (UV) and has natural anti-bacterial properties. Hemp is used to make rope, canvas and paper; it can also be woven to make linen-like fabric used in clothing, home furnishing textiles and floor coverings. It is also used to reinforce molded thermoplastics in the automobile industry. There is an increasing



awareness of hemp fibre and a wide spectrum of hemp products are now available in the market, made of different parts of the plant.

- XIII. France, Germany, China are among the major producers. Production of hemp is restricted in some countries, where it is confused with marijuana.
- XIV. **Flax:** Flax fibre is stronger, crisper and stiffer to handle compared to cotton. It can absorb and release water quickly, making linen comfortable to wear in hot weather. Linseed/ flax are cultivated exclusively for seed and oil in India. However, Indian varieties have 20-25% good quality flax fibre. It is produced in Madhya Pradesh, Uttar Pradesh, Bihar, Chhattisgarh, Jharkhand, Orissa and other states. India recorded 0.14 million tonnes (estimated-Ministry of Agriculture) production of linseed in FY08.
- XV. India does not have significant presence among the flax fibre producing countries. India is importing flax fibre to meet demand for flax from the defense sector.
- XVI. China, France, Belgium, Belarus and Ukraine are the major flax fibre producing countries. About 70% of linen manufactured is used in the textile industry. Lower fibre grades are also used as reinforcement and filler in thermoplastic composites.
- XVII. Coarse flax fibres are used for manufacture of strong ropes, shipping cord, twines and cordage, kitchen towels, sails, tents and canvas. Fine grade flax fibre is used for manufacturing of good quality suiting-shirting materials, cloth laces, household textiles, others. It is also used in admixture of cotton. Lower fibre grades are used as reinforcement and filler in thermoplastic composites.
- XVIII. **Ramie:** Ramie fibre is one of the strongest natural fibres, is white in color, with a silky luster, has low elasticity and dyes easily. India has many varieties of ramie and is found across a number of North-Eastern states, Uttarakhand and Himachal Pradesh. However, ramie is commercially produced only in some parts of Assam, North Bengal and Maharashtra in the country.
- XIX. China is the biggest producer of ramie fibre followed by Brazil and Philippines. Ramie prices are showing an increasing trend due to its popularity and limited supply in international markets. The ramie plant is grown for fibre mainly in China, Brazil, the Lao PDR and the Philippines.
- XX. The yarn produced from ramie fibre is suitable for a wide range of garments. It is usually blended with other textile fibres. It is also suitable for making twine, rope and nets.
- XXI. **Bamboo fibre:** Bamboo fibre is strong, flexible, can be softer than silk when spun into yarn and also has natural anti-bacterial properties. Bamboo fibre has numerous applications, which includes clothing, non-woven fabric (used in hygiene materials), home furnishing and medical textiles. India, China and Japan are among the major producers of bamboo in the world.



- XXII. **Korai:** Korai (*Cyperus pangorei*) is an aquatic perennial plant, belonging to the Cyperus family. It is used to make different utility products like bags, bins, boxes, mats, etc. It is found abundantly in some parts of south India. They are also used for thatching, fencing, potpourri and perfumery. Some species also have medicinal properties, while others have the potential for use in erosion control and sand stabilization.
- XXIII. **Screw pine:** Screw pine fibre is obtained from the leaves of the screw pine plant. Screw pine plant is found abundantly in Kerala, Tamil Nadu, Orissa, Andaman and Nicobar. The commercial exploitation is done mainly in different parts of Orissa, Tamil Nadu, Kerala, Andhra Pradesh, West Bengal and Uttar Pradesh. Screw pine leaves are twined, inter-looped, woven and braided to make different products like mats, boxes, hats, bags, etc.
- XXIV. **Water hyacinth fibre:** Water hyacinth fibre is obtained from the stems (stalks) of the water hyacinth plant. Water hyacinth is available across all the parts of the world. In India this weed was introduced in 1896 as an ornamental piece at the botanical garden in Bengal. India has not yet fully explored the potential of this plant except for some groups in South India. In India, water hyacinth is traditionally used for manufacturing paper (under cottage industry), baskets, and matting and for animal fodder. It is also used as vermi-compost in some parts of the country.
- XXV. Water hyacinth is generally considered as an ecological hazard. However, it also finds diverse applications in various countries. Philippines's Department of Science and Technology's, Philippine Textile Research Institute is undertaking studies on use of water hyacinth fibre as a raw material for the manufacture of clothing and fabrics.
- XXVI. **Pineapple fibre:** Pineapple fibre is white, creamy and lustrous as silk fibre and is 10 times as coarse as cotton and the fibre can easily retain dyes. India is the sixth largest producer of pineapples in the world. The major pineapple producing states in India are West Bengal, Assam, Karnataka, Bihar, Tripura and Kerala. In India, the manual process employed for extracting fibre is very laborious. Also, there is a great need for marketing activities to promote pineapple fabric in India.
- XXVII. Pineapple plants are largely grown in tropical America, in Far-East Asian countries and Africa. In Philippines and Taiwan, the pineapple plant is largely used as a source of fibre. In India, also the pineapple plant is used as a source of fibre.
- XXVIII. Pineapple fibre is used for making cloth and is also at times combined with silk or polyester to create textile fabrics. Pineapple fibre is also used for table linens, bags, mats and other clothing items. It finds different uses across the various parts of the world. There is huge potential for pineapple fabric, given its diverse uses and eco-friendly properties.



RECOMMENDATIONS OF THE SUB-GROUP FOR OTHER NATURAL FIBRES

- XXIX. The Other Natural Fibres are of vital importance due to various factors which includes, potential to provide farm and off-farm based employment to large section of the population, utilization of the so-called 'waste' to generate wealth thus providing additional avenue for livelihood generation, allows for green economy, which would also add to the green cover of the country, amongst others.
- XXX. The major policy interventions/recommendations suggested by the sub-group on Other Natural Fibres are as follows:
12. The sub-group is in consensus that the policy intervention in the first phase ought to be limited to five other natural fibres, viz., Banana fibre, Pineapple fibre, flax, sisal and Hemp/Nettle.
 13. In addition to the five fibres mentioned in the above point, there are a number of other natural fibres, such as screw pine, water-hyacinth, ramie, palm leaf and Korai grass which are available in India and have varied usage across different product categories. In order to promote these other natural fibres, this sub-group recommends that **another focus study** may be taken up to devise promotional mechanisms for them.
 14. India has a rich variety of other natural fibres, however data and information on the same is not readily available. Given the huge potential these other natural fibres hold in terms of demand and their contribution to the overall economic growth of the country, the sub-group recommends a **national-level census** to gather exhaustive information on other natural fibres in India.
 15. The recommendations/policy interventions suggested by the sub-group for the selected five other natural fibres include:
 - a. To ensure promotion of the five selected other natural fibres, the sub-group proposes a '**Focus Fibre Focus State**' approach, under which the promotion of each selected fibre would be carried out in a selected state. The FFFS approach is specific for each selected fibre, as the selected fibres/plants are either already cultivated in large quantities (Banana and Pineapple) or are available, but not commercially exploited or needs to be promoted (Sisal, Flax, Hemp / Nettle). Based on the above factors, the selected fibres have been divided into two groups, Group I – Banana fibre and pineapple fibre and Group II- Sisal, flax, hemp/nettle for undertaking measures for their overall development.
 - i. Short-term strategies for Group I
The sub-group recommends that the government provide a capital subsidy of 50% to the industrial investors as an incentive for setting up the industry to consume



natural fibres, undertake research and development activities to ensure improved and efficient extraction and processing of the fibres, undertake a 5-year pilot program under the 'Cluster approach' to promote livelihood and economic development of the fibres at the local level. The learning from the pilot projects would be replicated at a pan-India level.

ii. Short-term strategies for Group II

For Group II fibres, the sub-group recommends undertaking of research and development programmes on raw material resources for breeding, standardization of nursery practices and fibre extraction techniques. It also recommends undertaking a 5-year pilot program under the 'Cluster approach' for the fibres at the selected state. The learning from the pilot projects would be replicated at a pan-India level.

b. In addition to the above the sub-group has recommend a number of other policy interventions for the development of Group I & II fibres. These include measures for:

- iii. Capacity building/training
- iv. Creation of necessary infrastructure
- v. Aggressive international marketing
- vi. Brand building and brand promotion measures
- vii. Fiscal measures
- viii. Enhance competitiveness

c. To accelerate THE development of Group I and II fibres, the sub-group proposes a holistic approach under intermediate strategy for initial 5 years. This holistic approach includes development strategies, identification and transfer of best practices, implementation of program, documentation and standardization of practices gained in the immediate strategies which will further pave the way for the long term mission.

d. For development of these fibres in the long-term the sub-group proposes a 'National Other Natural Fibres Mission' to replicate best practices (gained from the Focus Fibre Focus State Approach) on a pan India basis based on the census data and the findings / lessons gained from the intermediate strategy. Therefore, sub-group proposes a detailed study to evolve the objectives, structure, focus, functioning and funding for a long term 'National Other Natural Fibres Mission' in concurrence with the intermediate strategy.

6.1. NATURAL FIBRES

OVERVIEW

- 6.1.1. Natural fibres can be defined as bio-based fibres or fibres from vegetable and animal origin. Based on their origin, natural fibres can also be classified as cellulosic (from plants) and protein (from animals). Excluded here are mineral fibres such as asbestos that occur naturally but are not biobased. Other natural fibres as defined for this policy are of plant origin, cellulosic and renewable.

Exhibit 6.1.1: Categories of natural fibres	
Source	Fibre
Animal	Alpaca, Angora, Camel hair, Cashmere, Catgut, Chiengora, Llama, Mohair, Pashmina, Qiviut, Rabbit hair, Silk, Sinew, Spider silk, Wool, Vicuna, Yak
Vegetable	Abaca, Bamboo, Coir, Cotton, Flax, Hemp, Jute, Kenaf, Piña, Raffia palm, Ramie, Sisal, Wood, Banana, Pineapple

- 6.1.2. Globally, cotton is the largest natural fibre produced with an estimated average production of 25 million tonnes during recent years. Wool and jute account for around 2-3 million tonnes of production per year. Other natural fibres are produced in considerably smaller volumes. Trade markets and exports of natural fibres such as sisal and henequen, jute, kenaf, flax and hemp have seen a decline in the past decades, which is often attributed to the introduction of cheaper synthetic substitutes.

Exhibit 6.1.2: Estimated global production volume averages of different natural fibres (in million metric tonnes per year average over the recent years)		
Fibre	Million tonnes	Main producer countries
Cotton	25.00	China, USA, India, Pakistan
Jute	2.50	India, Bangladesh
Wool	2.20	Australia, China, New Zealand
Flax	0.50	China, France, Belgium, Belarus, Ukraine
Kenaf	0.45	China, India, Thailand
Coir	0.45	India, Sri Lanka
Sisal	0.30	Brazil, China, Tanzania, Kenya
Ramie	0.15	China
Hemp	0.10	China



Exhibit 6.1.2: Estimated global production volume averages of different natural fibres (in million metric tonnes per year average over the recent years)

Fibre	Million tonnes	Main producer countries
Abaca	0.10	Philippines, Ecuador
Silk	0.10	China, India
Kapok	0.03	Indonesia
Henequen	0.03	Mexico

Proceedings of the symposium on natural fibres October 2008

VARIOUS NATURAL FIBRES

Banana fibre

- 6.1.3. Banana is a tropical crop. The banana pseudo stem is a major source of banana fibre, a natural fibre with high strength, which can be easily blended with cotton or other synthetic fibres to produce blended fabric and textiles. Given its considerable strength, the banana fibre is also used in production of high quality security/currency paper, packing cloth for agriculture produce, ship towing ropes, wet drilling cables, and other applications. Philippines and Japan are using banana fibre on a large scale for commercial production of a variety of textile items.

Palm leaf

- 6.1.4. Palms are perennial in nature and the palm leaves are a major source of natural fibre. Of the different varieties, the most important palm leaf is Palmyra palm. It is commonly cultivated in India, Southeast Asia, Malaysia and intermittently in other warm regions including Hawaii and Southern Florida. Palm leaf fibre is used to make ropes, mats, brushes, fish nets, brooms, amongst others.

Sisal

- 6.1.5. Sisal is the leaf fibre of the plant *Agave sisalana*, a plant which can withstand extreme climatic conditions, grow in drought prone and uncultivable, arid and mountainous conditions. The fibre is a hard, coarse fibre which is strong, durable, does not absorb moisture and can accept a wide range of dyes. The major producers are Brazil, Tanzania and Kenya. The fibre has numerous applications such as making of twines and ropes, handicrafts, geotextiles, specialty paper, filters, mattresses, carpets and wall coverings and as reinforcement in plastic composite materials and furniture. By-

products from sisal extraction can be used for making bio-gas, pharmaceutical ingredients and building material.

Hemp

- 6.1.6. Hemp fibre is obtained from the bast of the plant, *Cannabis sativa* L. It grows easily to a height of 4 meters without agrochemicals and captures large quantities of carbon. Hemp fibre is a good conductor of heat. It dyes well, resists mildew, obstructs ultra violet (UV) and has natural anti-bacterial properties. France, Germany, China are among the major producers. Production of hemp is restricted in some countries, where it is confused with marijuana. Hemp is used to make rope, canvas and paper, it can also be woven to make linen-like fabric used in clothing, home furnishing textiles and floor coverings. It is also used to reinforce molded thermoplastics in the automobile industry.

Flax

- 6.1.7. Flax fibre is obtained from the stems of the plant, *Linum usitatissimum* and is used mainly to make linen. Flax fibre like cotton is a cellulosic polymer, however compared to cotton, it is stronger, crisper and stiffer to handle. It can also absorb and release water quickly, making linen comfortable to wear in hot weather. The leading producers of flax fibre are France, Belgium and the Netherlands. Other significant producers are China, Belarus and the Russian Federation. About 70% of linen manufactured is used in the textile industry, which includes fabrics, high quality household textiles. Lower fibre grades are also used as reinforcement and filler in thermoplastic composites.

Ramie

- 6.1.8. Ramie fibre is obtained from the stem of ramie, a flowering plant of the nettle family. Ramie fibre is one of the strongest natural fibres, is white in color, with a silky luster, has low elasticity and dyes easily. The ramie plant is grown for fibre mainly in China, Brazil, the Lao PDR and the Philippines. The yarn produced from ramie fibre is suitable for a wide range of garments. It is usually blended with other textile fibres. It is also suitable for making twine, rope and nets.

Bamboo

- 6.1.9. Bamboo fibre is a cellulose fibre produced from bamboo pulp processed from bamboo culms. Bamboo fibre resembles cotton in its un-spun form and is thinner than hair. It is strong, flexible, can be softer than silk when spun into yarn and also has natural anti-bacterial properties. Bamboo fibre has numerous applications, which includes clothing, non-woven fabric (used in hygiene materials), home furnishing and medical textiles. India, China and Japan are among the major producers of bamboo in the world.

Korai grass

- 6.1.10. Korai (*Cyperus pangorei*) is an aquatic perennial plant, belonging to the Cyperus family. It can be plied into ropes of various thicknesses, which are then used to make different utility products like bags, bins, boxes, etc. It is found abundantly in some parts of south India.

Screw pine

- 6.1.11. Screw pine fibre is obtained from the leaves of the screw pine plant (*Pandanus-genus and Pandanaceae (screw pine family)*). This tropical plant is primarily found in Africa, Polynesia, Australia, Southern India, peninsular South East Asia, Indonesia and Western New Guinea, Coco islands, Sri Lanka, Myanmar and Bangladesh. Screw pine leaves are twined, inter-looped, woven and braided to make different products like mats, boxes, hats, bags, etc.

Water Hyacinth

- 6.1.12. Water hyacinth fibre is taken from the stems (stalks) of the water hyacinth plant (*Eichhornia crassipes*). The stalks of water hyacinth (*Eichhornia crassipes*) are a viable natural source of alternative textile material, according to the Philippine Department of Science and Technology's Philippine Textile Research Institute (PTRI). The usage of water hyacinth varies across counties. Yarn or rope made from this fibre is used to make furniture, baskets. Vietnam is major exporter of furniture made of water hyacinth.

Pineapple fibre

- 6.1.13. Pineapple fibre is made from the leaves of the pineapple plant which belongs to the family of Bromelia. Pineapple fibre is more delicate in texture than any other vegetable fibres. It is white, creamy and lustrous as silk fibre and is 10 times as coarse as cotton and the fibre can easily retain dyes. Brazil and Thailand are the largest producers of pineapple fibres in the world. Pineapple fibre is used for making cloth and is also at times combined with silk or polyester to create textile fabrics.

Cotton

- 6.1.14. The cotton fibre is obtained from the cotton plant, a variety of plants of the genus *Gossypium*. It is almost pure cellulose, absorbs moisture readily. Softness and breathability are its other major properties. Cotton is cultivated in around 80 countries and is one of the worlds' most widely cultivated crops. The major producers of cotton are China, Brazil, India, Pakistan, USA and Uzbekistan. These countries account for more than 80% of the total production of cotton. An estimated 60% of the cotton fibre is used as yarn and threads in a wide range of clothing. It is also used to make home furnishings

and is the most commonly used fibre in sheets, pillowcases, towels and wash cloths. It is also made into specialty materials suitable for a variety of applications.

Jute

- 6.1.15. Jute is extracted from the bark of the white jute plant, *Corchorus capsularis* and to a lesser extent from *C. olitorius* (tossa jute). Jute fibre also called as the “golden fibre” is one of nature’s strongest vegetable fibres and has high insulating and anti-static properties, moderate moisture regain and low thermal conductivity. Jute ranks second in terms of production. Bangladesh and India (West Bengal) are the main producers of jute in the world, with Myanmar and Nepal producing smaller quantities of jute. Of the various jute products manufactured, sacking contributes for the bulk. In addition, jute yarn and twines are also used for household textiles. It is also being blended with other fibres and used in cushion covers, toys, wall hangings, lamp shades and shoes. Use of jute in rigid packaging and reinforced plastic is increasing and is replacing wood pulp and paper. Geotextiles are also made from jute.

Coir

- 6.1.16. Coir is extracted from the tissues surrounding the seed of the coconut palm (*Cocos nucifera*) and is of two types, white coir and brown coir. Coir has a high concentration of lignin, making it stronger but less flexible than cotton and unsuitable for dyeing. It has good resistance to microbial action and salt water damage. India and Sri Lanka are the major producers of coir, where the coir industry is well developed. Vietnam, Philippines, Indonesia and Brazil are the other major producers of coir in the world. White coir is used in the manufacture of rope and used to make fishing nets, while brown coir is used in sacking, brushes, doormats, rugs, mattresses, insulation panels and packaging.

ECONOMIC IMPORTANCE OF NATURAL FIBRES

Employment

- 6.1.17. Globally, the natural fibres industry provides employment to millions of people, largely small scale (marginal) farmers and processors. Income from the industry contributes significantly to the income and food security of the poor farmers and workers in fibre industries. In some countries, the industry is of major importance to the national economy, such as cotton in some African countries – cotton is grown on two million farms employing over 10 million people in Sub-Saharan Africa, while in Asia, cotton is major source of income for some 100 million households. The jute industry in Bangladesh and sisal industry in Tanzania hold great economic significance to the respective country’s economy. In some countries, the industry is of lesser significance at the national level but is of great local

importance within a country. For example, alpaca fibre in the Andes, sisal in North-East Brazil and jute in West Bengal, India.

Environment friendly

- 6.1.18. Natural fibres are more environment friendly than synthetic fibres both in terms of production and their disposal. Unlike synthetic fibres which are largely produced from crude oil, a non-renewable source of energy, natural fibres are made of renewable resources. Natural fibres are carbon neutral; they absorb the same amount of carbon dioxide that they produce. Also, the wastes produced during processing of natural fibres are mainly organic wastes and residues that can be further processed to generate electricity or make ecological housing material. Natural fibres are completely bio-degradable. Natural fibre can thus play a key role in the emerging “green” economy²².

Due to the Kyoto protocol, global markets are in the process of transition towards a bio-based economy on green house gas reduction and carbon neutral production.

Medicinal properties/healthy choice

- 6.1.19. Natural fibres provide natural ventilation and also a number of natural fibres also have herbal medicinal properties. Coconut fibres (coir) used in mattresses has a natural resistance to fungus and mites. Hemp fibre has antibacterial properties and studies have shown that 100% knitted linen is the most hygienic textile for bed sheets²³. Hemp fibre is recommended for household textiles by Chinese scientists, as they believe that it has a high capacity for absorption of toxic gases.

NEED FOR A FIBRE POLICY

- 6.1.20. India has a presence of a number of other natural fibres however the same have not been fully commercially exploited. India does not have a significant presence in other natural fibres, though ramie, flax, linen are used by Indian textile industry. Leaf fibres such as agave (sisal) and fruit fibres such as coconut and palm and banana and pineapple fibres are yet another group of natural fibres that have huge potential. The Chinese textile industry uses a number of natural fibres. China produces a huge amount of natural fibres; however it still needs to import great quantities of fibres such as flax (agricultural production of flax in China can only supply around 40% of the raw materials to the factories) to meet the demand from its textile industry. Philippines has developed the pineapple industry well, while Kenya and Tanzania have developed their sisal fibre industry.

²² Presentation on International Year of Natural Fibres and Food Security – trends, issues and challenges

²³ International Year Of Natural Fibres



- 6.1.21. The natural fibres industry has faced increased competition, since the development of synthetic fibres in 1960s. The recent global economic slowdown has adversely affected the demand for other natural fibres. Given that this industry provides employment to millions of people in the country, especially the small scale/marginal farmers and processors, measures need to be undertaken to ensure growth for the industry in the medium to long term period.
- 6.1.22. The natural fibres industry faces the challenge of developing and maintaining markets where they can compete effectively with synthetics. Depending on the fibre, this could involve defining and promoting market niches, while in some cases, basic R&D would be required to develop new technologies to facilitate the use of natural fibres in new applications, where their natural advantages allow them to compete effectively with synthetics. In addition to the above general issues, there are several other issues that the natural fibre industry is currently facing, which require immediate attention and action. This policy attempts to/suggests ways/measures to provide these facilities to the other natural fibres industry keeping in view the regulatory requirements attached therewith.
- 6.1.23. In addition, there is a need to elaborate on the concerted interventions in policy areas for augmenting investment, support mechanisms on both fiscal and non-fiscal front, to attain the growth and competitiveness of this labour intensive manufacturing sector. Also, a mechanism needs to be defined which facilitates the required fibre availability to meet the growth targets of the textiles & garments sector.
- 6.1.24. The policy is intended to provide the necessary balance between the initiatives of the producers and the benefits of the consumers, across the various segments of the sector. There is a need to improve the overall functioning of the natural fibre industry by improving the technology, and fastening the manufacturing process along with aiding the provisioning of ancillary facilities.

6.2. PRESENT STATUS OF OTHER NATURAL FIBRES

- 6.2.1. The earlier chapter discusses in brief on 14 other natural fibres. This chapter would provide further insights on 10 of the 14 natural fibres considered in the earlier chapter. There are other sub-groups working on the natural fibres, cotton, jute and wool. In addition, work on bamboo is being undertaken in the country under the “National Bamboo Mission” and “National Mission on Bamboo Applications”

BANANA FIBRE

- 6.2.2. India is the world’s largest producer of banana. However the use of banana fibre in the textile industry and for other purposes is a relatively new concept in India. Abaca fibre which belongs to the same family as banana fibre is being used successfully in Philippines since decades and hence is also known as “Manila Hemp”. Philippines is the world’s largest producer of abaca fibre, while the crop is also cultivated in Ecuador and other Southeast Asian countries. Along with India, the other major banana producing countries in the world are China, Brazil, Ecuador and Indonesia. Philippines and Japan are the major banana fibre producing countries for large scale manufacturing of textile items made from banana fibre.

PALM LEAF

- 6.2.3. Palm leaves (source of fibre) are of different types, pinnate, palmate, bi-pinnate and entire. The most important economic palm with palmate leaves is the Palmyra palm (*Borassus flabellifer*). In India it is cultivated as a windbreak on the plains in India. Orissa has abundant number of palm trees, accounting for around 15-20% proportion of total palm trees in the country. Palm fibre is being exported to US, UK, Belgium, Philippines, Japan, Germany, Australia and Netherlands by the Tamil Nadu State Palmgur and Fibre Marketing Cooperative Federation and exporters from Thuthukudi in Tamil Nadu.

SISAL

- 6.2.4. Sisal industry in India is largely unorganised. Sisal is mainly grown in arid and semi-arid regions across the various states in the country. India is the 2nd largest importer and 5th largest exporter of sisal in the world. India exported 341 tonnes of sisal valued at US\$ 1.33 million in 2007, while it imported 1,951 tonnes of sisal valued at US\$ 2.33 million in 2007. Global production of sisal fibre has been around 0.3 million tonnes. Production came down from 270,500 tonnes in 2006 to around 247,800 tonnes in 2008. In terms of quantity, Brazil is the largest exporter of sisal fibre in the world

with volumes of around 52,600 tonnes. Exports from Brazil dropped drastically to 27,100 tonnes in 2008.

INDUSTRIAL HEMP

- 6.2.5. Global production of hemp is estimated to be around 0.1 million tonnes (per year average over the recent years). Europe and China are the major hemp producing regions in the world. Hemp is primarily cultivated only in some districts in Uttarakhand, Kashmir and Travancore. Currently, India is not strongly present in the map of hemp producing countries.

FLAX

- 6.2.6. Global flax fibre and tow production dropped to around 0.5-0.6 million tonnes during 2006-2007 from around 1.01 million tonnes during the preceding two years. Production recovered to 0.94 million tonnes in 2008. China has emerged as the biggest producer of flax fibre & tow, it registered production of 0.62 million tonnes in 2008. Trade in flax also witnessed declines during 2004-2007. Exports dropped from 0.25 million tonnes during 2004 to 0.2 million tonnes in 2007, while imports dropped from 0.22 million tonnes in 2004 to 0.18 million tonnes in 2007. Flax fibre accounts for around 2% of the production of natural fibres in volume terms.

RAMIE

- 6.2.7. Global production of ramie fibre is estimated to be around 0.15 million tonnes (per year average over the recent years). Ramie fibre accounts for around 0.8% of the production of natural fibres in volume terms and around 0.5% in terms of value. China is the biggest producer of ramie fibre followed by Brazil and Philippines. Ramie prices are showing an increasing trend due to its popularity and limited supply in international markets. India has many varieties of ramie and is found across a number of north-eastern states, Uttarakhand and Himachal Pradesh. However, ramie is commercially produced only in some parts of Assam, North Bengal and Maharashtra in the country.

KORAI GRASS

- 6.2.8. Korai (An aquatic ecosystem is an ecosystem located in a body of water. Communities of organisms that are dependent on each other and on their environment live in aquatic ecosystems...Cyperus pangorei) grows in marshes and wet lands mainly near rivers and lakes. It is green in color and normally grows to a height of 1-3 feet and can grow up to 5 feet in excellent conditions. It is also known as 'Kora grass' and is abundantly found in some parts of south India (Tamil Nadu, Kerala,



Andhra Pradesh, others). The culm (stem) of korai is flexible and pliable and if soaked in water its pliability increases. Given its pliable character, the grass can be plied into ropes of various thicknesses, which are then used to make different utility products like bags, bins, boxes, etc. For making mats, korai is sliced and further processed. The grass is also dyed to give an interesting combination of colors. They are also used for thatching, fencing, potpourri and perfumery. Some species also have medicinal properties, while others have the potential for use in erosion control and sand stabilization.

SCREW PINE

- 6.2.9. Screw pine plant is found abundantly in Kerala, Tamil Nadu, Orissa, Andaman and Nicobar. The commercial exploitation is done mainly in different parts of Orissa, Tamil Nadu, Kerala, Andhra Pradesh, West Bengal and Uttar Pradesh. For extracting the fibre, the screw pine leaves are cut with a knife and the thorns from the sides are removed. Cleaned leaves are divided into two halves without disturbing the original length of the leaves and they are boiled. After that, they are kept in fresh water overnight and the leaves are later dried. After drying the leaves become ivory in colour and are ready for fibre extraction.

WATER HYACINTH

- 6.2.10. Water hyacinth is available across all the parts of the world. It is generally considered as an ecological hazard. However, it also finds diverse applications in various countries. Yarn or rope (made of Water hyacinth fibre) is used to make furniture in Bangladesh and baskets in the Philippines. Water hyacinth has also been used for water purification as it can absorb heavy metals, organic compounds and pathogens from water. In South East Asia, water hyacinth is used as animal fodder to feed livestock. It is mixed with organic municipal waste, ash and soil, manure and sold to local farmers and market gardeners in Sri Lanka. It is also used in small-scale cottage industry papermaking projects in various countries like Philippines, Indonesia, and India.
- 6.2.11. Philippines's Department of Science and Technology's, Philippine Textile Research Institute is undertaking studies on use of water hyacinth fibre as a raw material for the manufacture of clothing and fabrics. Water hyacinth is spread almost all over the country. In India this weed was introduced in 1896 as an ornamental piece at the botanical garden in Bengal. India has not yet fully explored the potential of this plant except for some groups in South India. In India, water hyacinth is traditionally used for manufacturing paper (under cottage industry), baskets, and matting and for animal fodder. It is also used as vermi-compost in some parts of the country.



PINEAPPLE FIBRE

- 6.2.12. Global production of pineapple was around 19 million tonnes in 2008. Production of pineapple rose from 16.6 million tonnes in 2004 to around 21 million tonnes in 2007. Production declined in 2008. Pineapple plants are largely grown in tropical America in Far-East Asian countries and Africa. Brazil accounted for around 13%, while Thailand and Philippines accounted for around 12% of global pineapple production during 2008. In Philippines and Taiwan, the pineapple plant is largely used as a source of fibre. In India, also the pineapple plant is used as a source of fibre. In FY08, India produced 1.2 million tonnes of pineapple and the major pineapple producing states in India are West Bengal, Assam, Karnataka, Bihar, Tripura and Kerala.

6.3. POTENTIAL FIBRES

6.3.1. Of the ten other natural fibres studied in the earlier section, five fibres have been identified which hold great potential. These fibres have been discussed in detail in this chapter. The rationale for choice of these fibres is as follows:

- **Use in textile segment:** The primary criterion for the selection is the fibres should be used in the textile industry (convertibility into textiles).
- **Easy availability:** These fibres/plants are cultivated in India in fairly abundant quantity, and therefore are relatively easier to exploit for commercial purpose. Examples- Banana, Pineapple
- **High growth potential:** The selected fibres are currently being imported into India in a reasonably significant amount. Thus, this signifies domestic demand for these fibres, and replacement of the high imports is an opportunity. Examples- Flax and Sisal.
- **Neutrality to other crops:** These crops are already being largely grown, and thus do not pose a threat to acreage under the other crops and will use existing biomass.
- **State participation:** Active state participation is already present in these selected fibres, with considerable institutional support also available, thus allowing policy intervention to yield maximum benefit within a short period.
- **Existing human resource:** Traditional knowledge and existing human resource are already available for chosen fibres at local levels.

INDUSTRIAL HEMP

Introduction

6.3.2. Hemp fibre is cultivated from the plants belonging to the Cannabis genus. Cannabis sativa L has two varieties named Industrial hemp and marijuana. Marijuana typically contains 3-15% of the psychoactive ingredient called delta-9-tetrahydrocannabinol (THC) on a dry-weight basis, while industrial hemp generally have less than 1% of THC. However, the two varieties are very identical by appearance and are often cause confusion. United Kingdom, Germany, Austria, and Switzerland legalized production of hemp varieties containing less than 0.3% THC since 1990. However, Canada and Australia legalized hemp production in 1998. On the other side, China, Russia, and Hungary never prohibited hemp production in their respective countries.

6.3.3. Hemp is an annual plant and can grow on a wide spectrum of soils. It needs well drained, nitrogen rich and non-acidic soil. Hemp favors a mild climate, humid atmosphere and a rainfall of at least 25-30 inches (64-76 cm) per year. Soil temperatures must reach a minimum of 42-46°F (5.5-7.7°C) before seeds can be planted.

6.3.4. The following are the various types of hemp fibres.

- Primary bast fibre - long and low in lignin
- Secondary bast fibre - intermediate and high in lignin
- Libriform - short and high in lignin

6.3.5. Hemp fibres consist of 70% of cellulose and low levels of lignin around (8-10%). Its diameter could be in the range of 16-50 microns. Hemp fibre is a good conductor of heat. It dyes well, resists mildew, obstructs ultra violet (UV) and has natural anti-bacterial properties.

6.3.6. Optimum yield of hemp fibre is more than 2 tonnes per hectare, whereas, average yield is approximately 650 kilograms per hectare.

The following exhibit depicts the proportion of the green-plant and dry-plant components of hemp plant grown for fibre.

Exhibit 6.3.1: Green and dry plant components of hemp plant grown for fibre

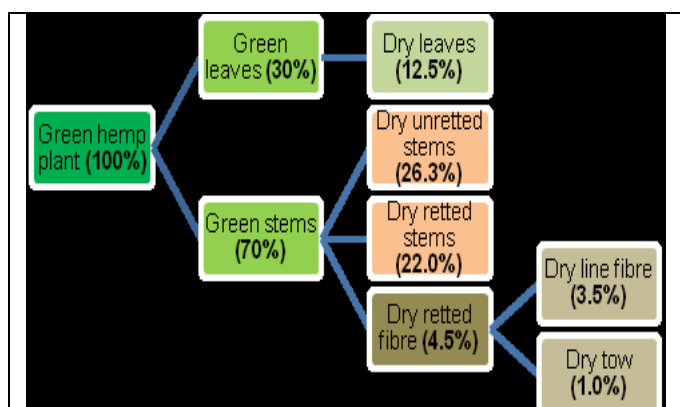

Source: USDA

6.3.7. Indian hemp is a full-bodied, tall, erect, annual herb, 1-5 meters in height, normally with male and female plants in approximately equal numbers. It has angular stems having palm-shaped or hand-shaped divided leaves with greenish flowers. Different products can be obtained from different parts of the plant - fibre from the stems, oil from the seeds and narcotic from the leaves and flowers.

Current status of technology, extraction techniques

- 6.3.8. Depending on the final product to be made, the harvesting and fibre processing, timing and technique varies. Hemp fibre manufacturing involves the following steps:

Harvesting

The fibre is ready around the time, when the plant starts developing its first seeds. Hemp plant is light sensitive. Thus, early plantings will produce taller crops and thus longer fibre.

Retting

Retting is process to separate fibres from bark tissue. It can be done through various methods.

Dew/Snow retting- Hemp stems are left in open, where rain, dew, irrigation or snow (prevalent in Uttarakhand in India) can keep the stems moist. This process may take up to 5 weeks and gives a coarse fibre which is light brown in color.

Water retting- Stem bundles are submerged in water for bacterial break down of pectin. It takes 7-10 days and produces better quality fibre.

Warm water retting- Stem bundles are soaked for 24 hours then these bundles are treated with heat for 2-3 days. This process gives very clear and uniform hemp fibres.

Chemical retting- In this process, chemicals are used to dissolve the pectin. This process takes approximately 48 hours and produces a very high quality product.

Industrial processing

- 6.3.9. After retting, the fibre is degummed, dried, decorticated, scutched, hackled and combed — processes that separate and clean the component parts so each part can be used for various purposes. 'Tows' are derived from the scutching and hackling process. The scotched and hackled tow is spun into coarse yarn or cord in a dry or wet spinning process subject to various levels of purity, including refining and parallelizing, by means of different carding machines (carding of different intensities). In India, carding is mostly done by hands. Traditionally, hemp processing plants are very small and labor intensive.
- 6.3.10. Efforts of 'Cottonisation' regarding hemp are already underway. In this process, hemp fibres are arranged in length and spin-technical characteristics similar to cotton (cottonisation), so that the processing of fibres can be carried out on cotton machines.



International scenario – Hemp fibre

- 6.3.11. Global production of hemp is estimated to be around 0.1 million tonnes²⁴ (per year average over the recent years). Hemp fibre accounts for around 0.2% of the production of natural fibres in volume terms and around 0.1% in terms of value. Europe and China are the major producing countries for hemp. China has a production of around 4,000 tonnes of refined hemp. The following table shows the hemp fibre production in European Union (EU) countries.

Exhibit 6.3.2: Hemp fibre production in European Union countries in 2005/06 campaign (in tonnes)*		
Countries	Hemp fibre production*	% Proportion
France	18,000	67.6
Germany	3,768	14.2
Spain	2,047	7.7
United Kingdom	1,062	4.0
Austria	547	2.1
Hungry	482	1.8
Czech Republic	300	1.1
Poland	233	0.9
Netherlands	100	0.4
Italy	88	0.3
Total	26,626	

Source: *International Conference on Flax and Other Bast Plants, 2008*

Present status in India

- 6.3.12. Hemp is primarily cultivated in the districts of Almora, Chamoli, Garhwal and Nainital (excluding the Terai and Bhabar) in Uttarakhand in the country. It is also produced in Kashmir and Travancore to a small extent. The limited cultivation in selected parts of the country is mainly due to requirement of low soil temperature at the time of planting.
- 6.3.13. Currently, India is not strongly present in the map of hemp producing countries. To improve this situation, many efforts need to be undertaken in a consistent manner. In India, raw materials are

²⁴ Common fund for commodities – Proceedings of the symposium on natural fibres, October 2008



generally sourced from naturally growing plants. Degumming process takes a lot of time followed by carding process by hands for yarn making. Research and other trials are also in process regarding carding and spinning by machines.

Fiscal structure

Exhibit 6.3.3: Customs duty on hemp						
HS code	Item	Basic duty	CVD Ad. Val.	Education Cess @ 3%	Special Addl. CVD @ 4%	Total Duty Ad. Val.
53021000*	True hemp, raw or retted	30.0	8.0	1.21	5.66	47.28
53082000*	True hemp yarn	10.0	8.0	0.56	4.77	24.14

Note * - As of July 2009

Source: www.infodriveindia.com

- 6.3.14. Excise on true hemp (raw or retted) is levied at the rate of 8% (cenvat). There is additional excise cess of 3% is also levied.

Issues related to technology, R&D, storage and etc.

- 6.3.15. There is an urgent need for raw material assessment and skill development in hemp producing regions. Standardization of cultivation, fibre extraction, spinning and weaving practices should be conducted to achieve better yield, quality and realization.

Applications and market potential

Uses of hemp

- 6.3.16. Hemp has been used for centuries to make rope, canvas and paper. Long hemp fibres can be spun and woven to fine quality fabric used in clothing, home furnishing textiles and floor coverings. Hemp is primarily used for paper manufacturing in Europe due to low lignin content. Hemp fibres are also used in automobile industry for reinforcing molded thermoplastics. The short fibres (tow) are used for manufacturing insulation products, fibre board and erosion control mats. The fibrous core can be blended with lime to make strong and lightweight concrete.

Market potential

- 6.3.17. There is an increasing awareness of hemp fibre and a wide spectrum of hemp products are now available in the market, made of different parts of the plant – long bast fibre, medium fibre, short core fibre and seed oil.
- 6.3.18. Long fibre has long, strong strands (superior to cotton) suitable for textiles; has anti-mildew and anti-microbial properties that are particularly useful for sails, tarp, awnings and carpets. Moreover, it is biodegradable and serves as an environment-friendly substitute for fibre glass. Hemp fibre is used for a variety of textile products, such as bedspreads, blankets, backpacks, carpets, clothing, draperies, hats, luggage, mattresses, sails, sheets, shoes, shirts, tents, towels and upholstery. Hemp textiles have a number of distinct advantages over other fabrics like hemp textiles are longer, stronger, more lustrous and absorbent and more mildew resistant than cotton textiles.
- 6.3.19. Medium fibre has low lignin levels that make it ideal for paper and non-woven applications. The German Aerospace Institute and many German and American automobile companies are using hemp extensively for making auto components such as gaskets, seat covers, floor mats, and interior paneling. Fibre composites are among the fastest growing segment of the wood-products industry, thus showcasing the huge potential market for industrial hemp.

FLAX FIBRE

Introduction

- 6.3.20. Flax is known as linseed and alsī, tisi (Hindi). The other common names of flax are- lin, llin, liner, linum, linen, lein and lan. The cultivated linseed, *Linum usitatissimum* L. belongs to family Linaceae and is the only species of that family which is of economic importance.
- 6.3.21. Flax is an annual plant with a slender glabrous, greyish green stem. It grows to a height of about 3 to 4 feet and is about 1/6 to 1/8 inches in diameter. Flax is found in various varieties differing in their branching habits; those cultivated for seed have many branches and are bushy in nature, whereas those grown for fibre normally have branches only towards the top of the stem.
- 6.3.22. The quality of flax is determined by the weather conditions during its growth. Cool weather (March-June) followed by warm dry weather in July provides excellent production conditions for flax fibre. A temperate and equable climate, free from heavy rains and frost is desirable for proper cultivation of flax. A hot dry summer produces a short and harsh but strong fibre, whereas a moderately moist

summer produces fine but strong silky flax. Content of long fibres (in the straw) is directly proportional to rainfall during the growing months – higher the rainfall, higher the content of long fibres in the straw. The minimum temperature during the growing season is about 50⁰ F and maximum temperature is about 100⁰ F. The best type of soil for fibre flax is good loamy soil which can be ploughed to a depth of 6 to 7 inches and has a firm clay sub soil.

6.3.23. In India flax / linseed is a winter crop. It grows equally good in both the peninsular region of the south and the alluvial soil of the north region. The crop settles well on deep moisture retentive soils when the cold season is favorable. It is cultivated in different parts of the country with diverse climate and soil conditions. A relative humidity of 60-70% at midday and with this around 6-8 inches of rain spread evenly over the three growing months is considered ideal for flax.

Flax is normally produced either for fibre or for seed. The varieties of fibre flax are classified generally into those with white, blue or purple flowers.

- White flowered variety- Generally more hardy and gives a higher yield per acre (both for fibre and seed).
- Blue flowered variety- Harsher fibre and of lower quality from the spinning point of view.
- Purple flowered variety- Not used extensively for actual commercial production

6.3.24. The taller five stemmed varieties of flax are grown for fibre production while the shorter branching varieties are grown for linseed oil. Some promising varieties produced in various countries in Europe are *Concurrent, Liral, Stormont, Are-en-ciel, Fortex, Nobles, Diana, Solid* etc. *Liral prince* and *Weira* are hybrid varieties. The following chart shows the proportion of chemical constituents present in flax fibre.

Exhibit 6.3.4: Proportion of Chemical constituents in flax fibre

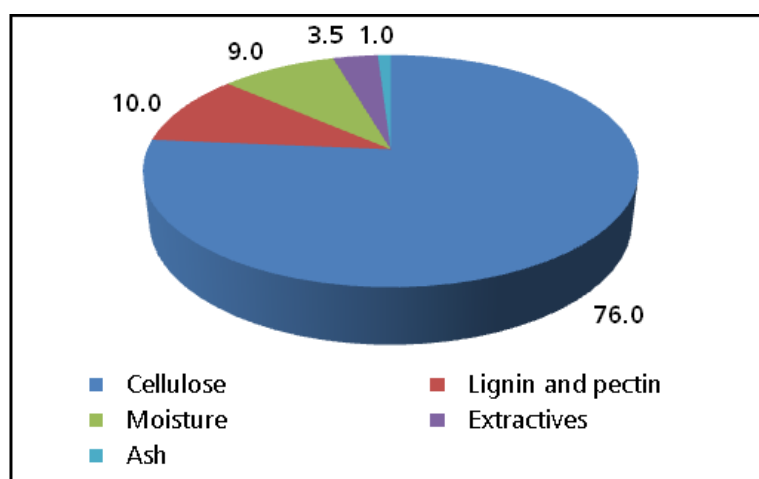



Exhibit 6.3.5: Elements present in flax fibre		
Name of the element	Element concentration (PPM)	
	Grey flax fibre	Bleached flax fibre
Sodium	22	11.5
Potassium	166	143
Calcium	297	296
Silicon	66	38.5
Magnesium	15	12.2

Large quantity of calcium and silicon present in the flax fibres adversely affect the drapability and washability of the finished product.

Current status of technology, extraction techniques

- 6.3.25. Fibre quality depends on the process of extraction. Extraction generally includes separation of fibre from the adhesive substances such as pectin or lignin, wax, resin, fats, and other carbohydrates. The following steps are included in flax fibre manufacturing.

Harvesting

- 6.3.26. Flax is harvested just before the seed is ripe. The plants are pulled out of the field either by hands or by machines. Stalk cannot be cut to avoid loss of fibre quality. These stalks are tied in bundles (called *beets*). Seeds and leaves are removed after drying by a process called rippling (passing the stalks through combs). In the next step, the plants are left in open to ferment for some weeks. Later, the fibre is extracted from the stalks by different retting processes.

Retting

- 6.3.27. Retting is the process to separate fibres from flax stem. It can be done through various methods.
- Stream/Water retting- This retting method gives the best flax quality fibres. Bundles of flax straw are dipped in streams of cool soft running water for 5-15 days. For efficient retting, water should be clean, and free from minerals (especially iron), which may stain or discolor the fibre. The fibre produces strong superior linen of pale yellow color. Water retting is common in India.



- Dew retting- Flax straws are left in open on the grass for 4-8 weeks, where dew keeps the straws moist. Dew retting involves the decomposition of pectin by enzymatic hydrolysis by fungi and bacteria. This method produces strong fibre grey in color. Dew retting is preferred in Europe, due to its low cost and environment friendliness.
- Tank retting- It is carried out in specialty built tanks for 2-3 days. Over retting is caused due to stagnant pools of water resulting in brittle and weak flax fibre. This method requires less time than dew retting.
- Chemical retting- Chemicals like soda ash, oxalic soda and caustic soda in warm water or boiling water in dilute H_2SO_4 solution are used in this retting. Drying is necessary to prevent over-fermentation. It takes lesser time but affects the strength and quality of fibre.
- Double retting- Retting is done in two phases and takes a few months to be completed resulting in a slow and gentle retting process and hence produces good quality flax fibre.
- Enzyme retting- Flax stalks are immersed in enzyme mixture
- Flash hydrolysis- This method is based upon a technique used in the paper industry and it produces a finer fibre with a lower content of non cellulosic material. This method produces fibre of greater productivity of spinning.
- Other methods of retting are chemical desiccation of standing crop, bacteriological, chemical enzymatic and hydro-thermo chemical retting processes.

Processing

6.3.28. Processing of flax fibre includes the below mentioned steps.

- **Breaking** - After retting, fibre is cleaned and dried. Decomposed woody tissue is crushed by iron rollers to convert stalks into small pieces of bark called *shives*.
- **Scutching** - Scutching involves removing of broken shives by machines or by hand to remove fibre from the stalk completely.
- **Hackling (Combing)** - Hackling (Combing) is a process of separating the long flax fibres (line) from the short fibres (tow). To get the fine quality, hand combing is preferred over more faster and efficient machine combing. Now the fibres are ready for spinning into yarn.
- **Spinning** - It can be done in two ways- dry and wet spinning. Dry spinning is used to produce coarse, heavy and in-expensive linen fabrics, while wet spinning (passing the roving through hot water) produces fine yarn of high count.



6.3.29. The following diagrams showcase the separating of rolled flax layers and processing of flax stems.

Exhibit 6.3.6: Processing of flax fibre

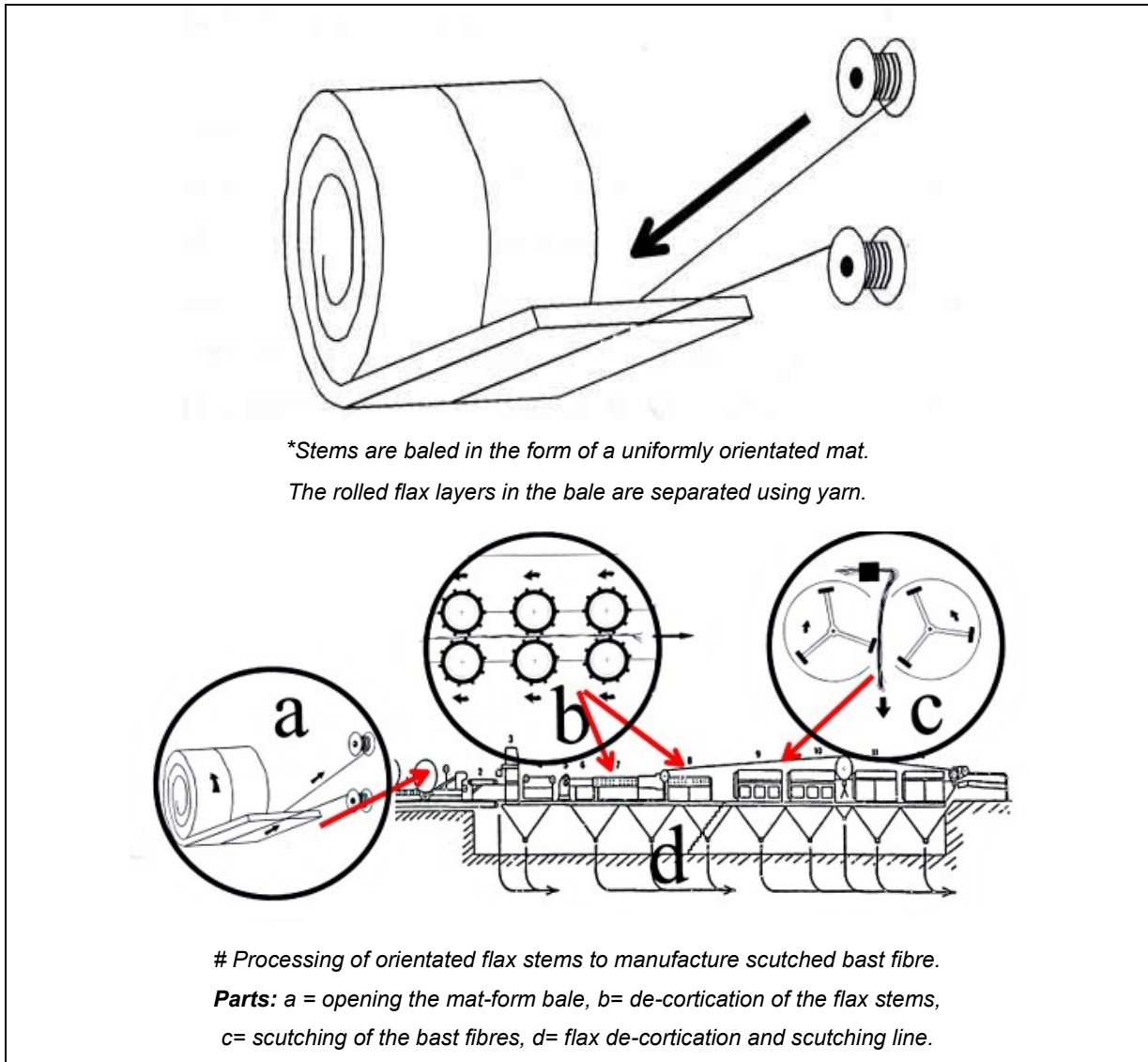

Source: University of Helsinki

International scenario – Flax fibre

6.3.30. Global production of flax fibre is estimated to be around 0.5 million tonnes²⁵ (per year average over the recent years). Flax fibre accounts for around 2.5% of the production of natural fibres in volume terms and around 1.2% in terms of value. China, France, Belgium, Belarus and Ukraine are the major flax fibre producing countries. The cultivation area of linseed (source crop of flax fibre) is around 4.9 million hectares in world map.

²⁵ Common fund for commodities – Proceedings of the symposium on natural fibres, October 2008



6.3.31. Global flax fibre and tow production registered a 72.9% growth in 2008 to 0.94 million tonnes. China recorded production of 0.62 million tonnes production in 2008. Global exports and imports of flax fibre and tow were 0.2 and 0.18 million tonnes respectively in 2007.

Exhibit 6.3.7: Overall global production trend in flax fibre and tow production (in million tonnes)

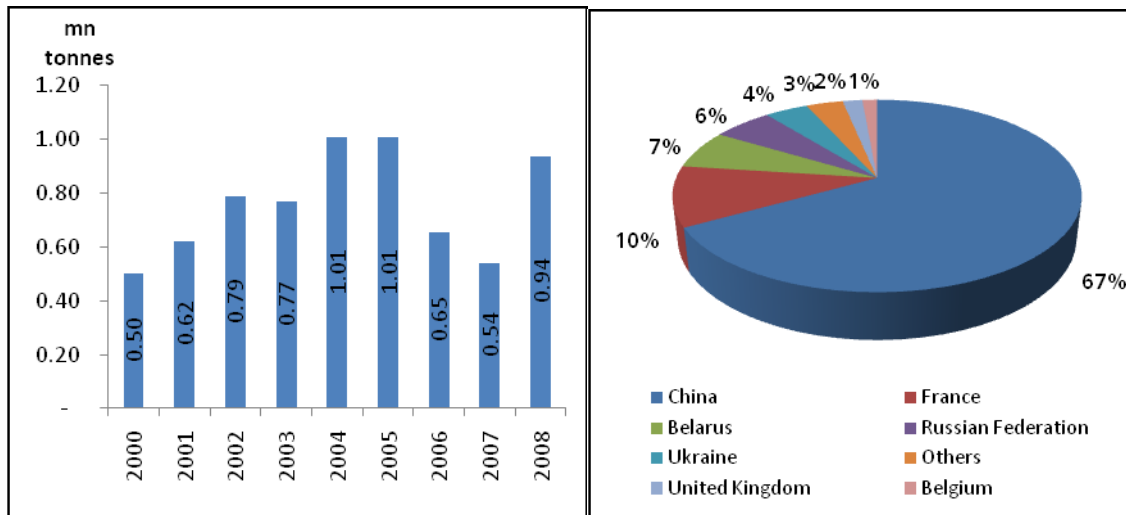

Source: FAO stats

Exhibit 6.3.8: Global exports-imports trend in flax fibre and tow (in million tonnes)

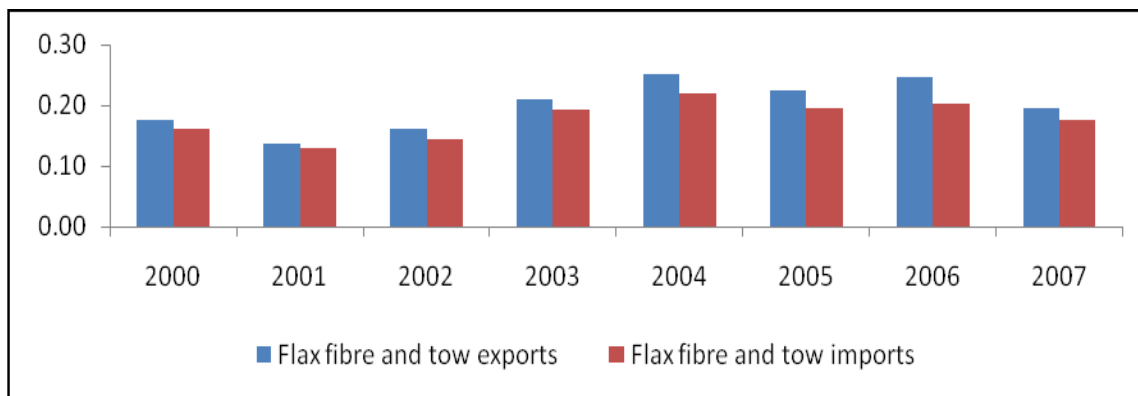

Source: FAO stats

6.3.32. France emerged as a largest exporter and China was the biggest importer of flax fibre and tow in 2007. India had only 2.1% proportion in total imports of flax fibre and tow in 2007.



Exhibit 6.3.9: Country-wise imports and exports of flax fibre and tow in 2007

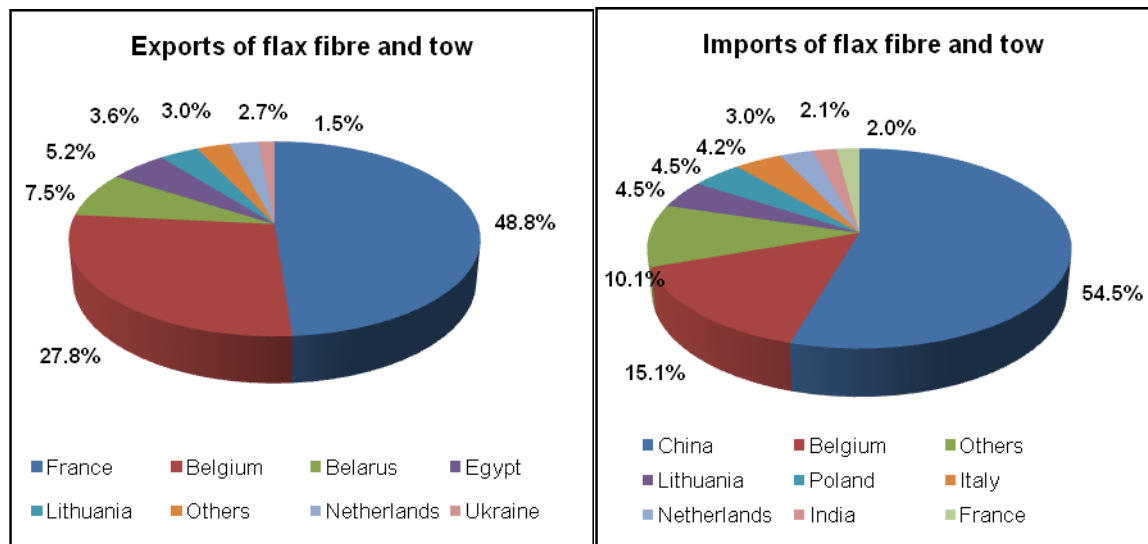

Source: FAO stats

Present status in India

6.3.33. Linseed/ flax are cultivated exclusively for seed and oil in India. However, Indian varieties have 20-25% good quality flax fibre. The Indian flax fibre shows luster and depicts Z twist on dyeing. It is produced in many states like Madhya Pradesh, Uttar Pradesh, Bihar, Chhattisgarh, Jharkhand, Orissa and other states. India recorded 0.14 million tonnes (estimated-Ministry of Agriculture) production of linseed in FY08.

Exhibit 6.3.10: Linseed production scenario in different Indian states in FY08

States	Area (' 000 Hectare)	Production (' 000 tonne)	Yield (Kg/hectare)
Andhra Pradesh	1	0	-
Assam	8	4	500
Bihar	27.8	23.5	845
Chhattisgarh	59.3	18.2	307
Himachal Pradesh	1.6	0.4	250
Jammu & Kashmir	0.1	0.1	1,000
Jharkhand	31.6	12.3	389
Karnataka	14	5	357
Madhya Pradesh	104	32.8	314



Exhibit 6.3.10: Linseed production scenario in different Indian states in FY08			
States	Area (' 000 Hectare)	Production (' 000 tonne)	Yield (Kg/hectare)
Maharashtra	68	19	279
Nagaland	10.2	6.8	667
Orissa	27.2	11.9	438
Punjab	0.1	0.1	1,000
Rajasthan	0.7	0.6	857
Uttar Pradesh	108	27.1	251
West Bengal	5.9	1.6	271

Source: *Indiastat.com*

- 6.3.34. The linseed oil is considered as technical grade oil. Around 20% of linseed oil is used for edible purposes in certain parts of India and the rest is used for preparation of paints, varnish and allied products. The linseed cake is considered a nutritious feed for milch cattle.

Fiscal structure

Exhibit 6.3.11: Customs duty on flax						
HS code	Item	Basic duty	CVD Ad. Val.	Education Cess @ 3%	Special Addl. CVD @ 4%	Total Duty Ad. Val.
53011000*	Flax, raw or retted	30.0	0.0	0.9	5.24	36.14
53061010*	Flax yarn (single: put up for sale)	10.0	8.0	0.56	4.77	24.14

Note * - As of July 2009

Source: *www.infodriveindia.com*

- 6.3.35. Excise on flax (raw or retted) is nil, while 8% Cenvat and 3% excise cess is levied on flax yarn (single: put up for retail sale).

Applications and market potential

- 6.3.36. Coarse flax fibres are used for manufacture of strong ropes, shipping cord, twines and cordage. Fine grade flax fibre is used for manufacturing of good quality suiting-shirting materials, cloth laces, bed sheets, damasks, curtains and similar materials. It is also used in admixture of cotton. The rest 80% left over substance after extraction of fibre (20% of dry scutched straw) has a potential of providing raw materials for manufacture of good quality writing paper, parchment paper, cigarette paper and straw boards (all grades) on economic basis.
- 6.3.37. Fine and regular long flax fibres are used in spinning of yarns for linen textiles. Above 70% of linen is used in textile manufacturing. Linen is always appreciated for its capability of exceptional coolness in hot weather. Linen fabric is also considered one of best fabric for manufacturing quality household textiles - bed linen, furnishing fabrics, and interior decoration accessories. Shorter fibres produce coarse yarns, used for manufacturing of kitchen towels, sails, tents and canvas. Lower fibre grades are used as reinforcement and filler in thermoplastic composites and thermo set resins for automotive interior substrates, furniture and other consumer products.
- 6.3.38. India does not have significant presence among the flax fibre producing countries. India is importing flax fibre to meet demand for flax from the defense sector, particularly. This demand could be fulfilled by domestic supply as India has good supply of linseed to produce flax fibre domestically.

CHINA- BRIEF PROFILE OF HEMP AND FLAX FIBRES

Flax fibre

- 6.3.39. China is the largest producer of flax fibre and tow and registered 0.62 million tonnes production in 2008. Chinese flax fibre industry (production) is more than 90 years old. Chinese textile processing capacity of bast fibres (Flax and hemp) is the best in the world. The agricultural production of flax can only supply 40% of the raw materials requirement of the processing factories in China.
- 6.3.40. The total cultivation area of flax fibre is around 65,000-75,000 hectares in China. The flax fibre straw yield is about 2.6 tonnes per hectare and long scotched fibre yield is less than 10%. Heilongjiang province has around 80% share in total flax fibre production. Over 90% of the straw is water retted and all the field production done by manual labor in Heilongjiang province.
- 6.3.41. There are more than 30 textile enterprises with a production capacity of 180,000 hasps and more than 2,000 looms. Their combine production capacity is second to Russia. At present, China has around

140 enterprises manufacturing raw flax materials with an annual field production capacity of its own fibre ranging at 40,000-50,000 tonnes.

- 6.3.42. China has undertaken efforts largely focusing on breeding and variety improvement and development. The China Science Committee launched a project to identify germplasm resources to store them in the 'National Germplasm Storehouse'. Currently, there are over 4,000 flax collections in China, including fibre, oil and both oil and fibre, wild flax, sterile flax and polyembryonic seeds. The main objectives behind this program are to identify and develop flax fibre breeding varieties of high yield, good quality, disease resistance and wide adaptability. It also focuses on expanding the long fibre content up to 19-20% with a total fibre content of 30%. The main breeding research activities are done at the Flax Research Institute under the Academy of Agricultural Sciences of Heilongjiang Province and The Institute of Industrial Crops in Heilongjiang, Hulan.
- 6.3.43. Under this program, the new Heiya fibre flax family of varieties has been developed. However, commencement of commercial production using these new Heiya varieties will be started in 3-5 years. Presently, European varieties (not well adapted) are being widely grown for fibre in China.

Hemp fibre

- 6.3.44. China is one of the major hemp fibre producing country. China produced around 4,000 tonnes of refined hemp. In recent years, China has developed two very low THC hemp varieties named Yunma 1 and Yunma 2. The THC content proportion meets the international standards for hemp.
- 6.3.45. China has successfully cottonised the traditional hard hemp fibres quite fine, soft and workable textile fibres similar to cotton. Currently, 2 kilograms of hemp fibres yield 1 kilogram of textile fibres in China. China has developed a group of degumming technologies and machines to cottonise the hemp fibres successfully for cotton as well wool system. These techniques and machines can also be efficiently used for blending with man-made fibres as well.



Exhibit 6.3.12: Machines developed for cottonisation of hemp in China



Source: FAO

- 6.3.46. China has also successfully developed the hemp viscose fibre (both filament yarn and staple fibres) from hemp core hurd (shiv). Hemp rayon staple is ideal for cotton textiles. Currently, 1 kilogram of viscose fibres can be produced from 3 kilograms of hemp core hurd.

BANANA FIBRE

Introduction

- 6.3.47. The banana pseudo stem²⁶ is a major source of banana fibre. Banana is a tropical crop. Optimum temperature range for banana cultivation is 15°C – 35°C with relative humidity of 75-85%. The

²⁶ Pseudo stem is a clustered, cylindrical aggregation of leaf stalk bases.



preferable climate for banana crop is tropical humid lowlands, although it can also grow at higher sea levels (up to an elevation of 2,000 meters above m.s.l). Banana is cultivated in climatic conditions ranging from humid tropical to dry mild subtropics in India by selecting suitable varieties. Banana crop is damaged at temperature below 12°C causing 'Chilling' injury. High velocity of wind (above 80 km/hr) also damages the crop. Healthy vegetative growth of banana critically depends upon 4 months of monsoon (June-September) with an average 650-750 mm rainfall. Few varieties like 'Hill banana' are suitable for higher altitudes.

6.3.48. Banana crop prefers deep, rich loamy soil with pH range of 6.5 – 7.5. Banana crop requires soil with good drainage, adequate fertility and moisture. A soil which is neither too acidic nor too alkaline, rich in organic material with high nitrogen proportion, sufficient phosphorus and potash level is good for banana, whereas saline solid and calcareous soils are not suitable for banana cultivation.

6.3.49. Around 70% of farmers are using suckers as planting materials and rest 30% farmers are taking tissue culture seedlings. Commercially, there are two types of banana - dessert types and culinary types.

Exhibit 6.3.13: Important banana varieties cultivated in different states of India	
State	Varieties grown
Andhra Pradesh	Dwarf Cavendish, Robusta, Rasthali, Amritpant, Thellachakrakeli, Karpoora Poovan, Chakrakeli, Monthan and Yenagu Bontha
Assam	Jahaji (Dwarf Cavendish), Chini Champa, Malbhog, Borjahaji (Robusta), Honda, Manjahaji, Chinia (Manohar), Kanchkol, Bhimkol, Jatikol, Digjowa, Kulpait, Bharat Moni
Bihar	Dwarf Cavendish, Alpon, Chinia , Chini Champa, Malbhig, Muthia, Kothia , Gauria
Gujarat	Dwarf Cavendish, Lacatan, Harichal (Lokhandi), Gandevi Selection, Basrai, Robusta, G-9, Harichal, Shrimati
Jharkhand	Basrai, Singapuri
Karnataka	Dwarf Cavendish, Robusta, Rasthali, Poovan, Monthan, Elakkibale
Kerala	Nendran (Plantain), Palayankodan (Poovan), Rasthali, Monthan, Red Banana, Robusta
Madhya Pradesh	Basrai
Maharashtra	Dwarf Cavendish, Basrai, Robusta, Lal Velchi, Safed Velchi, Rajeli Nendran, Grand Naine, Shreemanti, Red Banana
Orissa	Dwarf Cavendish, Robusta, Champa, Patkapura (Rasthali)
Tamil Nadu	Virupakshi, Robusta, Rad Banana, Poovan, Rasthali, Nendran, Monthan, Karpuravalli, Sakkai, Peyan, Matti
West Bengal	Champa, Mortman , Dwarf Cavendish, Giant Governor, Kanthali, Singapuri



6.3.50. Banana fibres have a major proportion (60-65%) of cellulose and single-fibre length is 80-200 mm. Other elements are cellulose, hemicellulose, and lignin. Its elongation is 3% and its mechanical and physical properties are similar to flax. Some physical and chemical properties of banana fibres are given below.

- Its appearance is similar to bamboo and ramie fibre; however banana fibre has better fineness and spin ability. It has shiny appearance depending upon the extraction & spinning process.
- It is very strong fibre with smaller elongation. It is light weight.
- Its average fineness is 2,400 Nm.
- It can easily absorb moisture as well as release moisture.
- It can be spun by different methods like ring spinning, open-end spinning, bast fibre spinning, and semi-worsted spinning.

Current status of technology, extraction techniques

6.3.51. Banana fibre can be extracted by manual stripping or machine stripping (by mechanical decorticator).

Manual stripping

6.3.52. Banana fibre is extracted from waste stalk of banana plant. Generally, banana fibre is situated near to the outer surface of the sheath and can be peeled-off easily in ribbons of strips of 5-8 cm wide and 2-4 mm thick along the entire length of the sheath. The stripping process is known as tuxying and the strips being called tuxies.

There are two methods of tuxying as prevalent in Philippines.

- Bacnis method

In this method, trunks are pulled apart and the sheath is separated as per their position in stalk. Then after, they are flattened and the fibre is stripped from the stem by cutting the pulpy part and pulling away the tuxy.

- Loenit method

In this method, tuxies are pulled off the stalk from one sheath at a time.

- After stripping, tuxies are bundled into bundles of 23-27 kg and brought to the stripping knife for cleaning. At last fibre is air dried and bundled for subsequent grading and bailing.



Machine stripping

- 6.3.53. In this method, trunks are cut into sections of 120-180 cm in length. The sections (one half the length at a time) are then crushed between rolls and the pulpy tissues are separated, by two large revolving drums, the rim of which are fitted with scrapping blade which peel-off the sheath while it is pressed against a bed plate, oven dried, graded and baled.

The following picture depicts the banana fibre extracting machine.

Exhibit 6.3.14: Banana fibre extracting machine

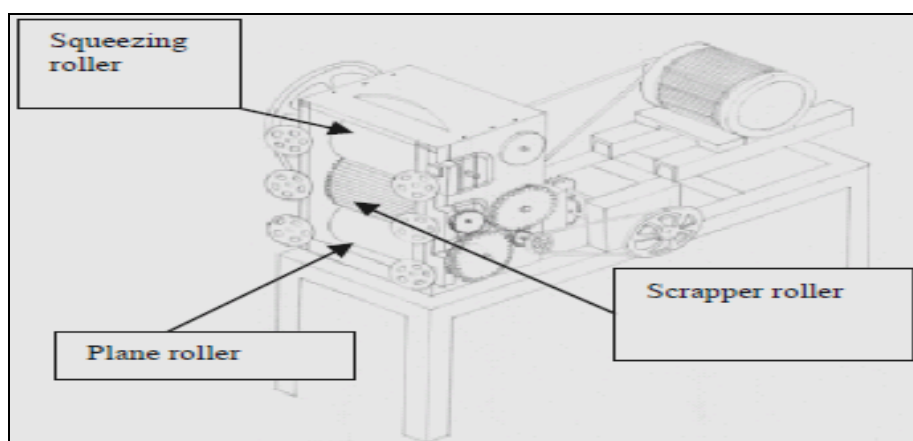

Source: *Journal of Engineered Fibers and Fabrics*-Volume 3, Issue 2—2008

Indian scenario

- 6.3.54. In Kerala, banana fibres are usually extracted manually by scrapping of the pithy material from pseudo stem with a wooden scraper. In the next step, fibres are cleaned and dried in shade. Only 1-2% wet weight per plant is available as fibres. It is estimated that 70 full-grown banana trunks gives 1 kilogram of dry banana fibre.

Exhibit 6.3.15: Manual extracting of banana fibres

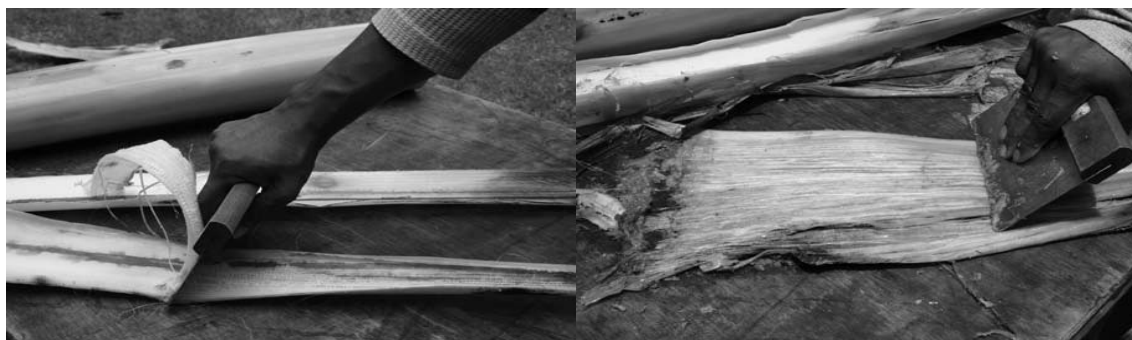

International scenario – Banana fibre

6.3.55. As such no data is available on global banana fibre production. However, data related to banana production and trade can be taken. India is the largest producer of banana with 32.8% share in total global production of banana in 2008. The other major banana producing countries are China, Brazil, Ecuador and Indonesia.

Exhibit 6.3.16: Overall global production trend in banana (in million tonnes)

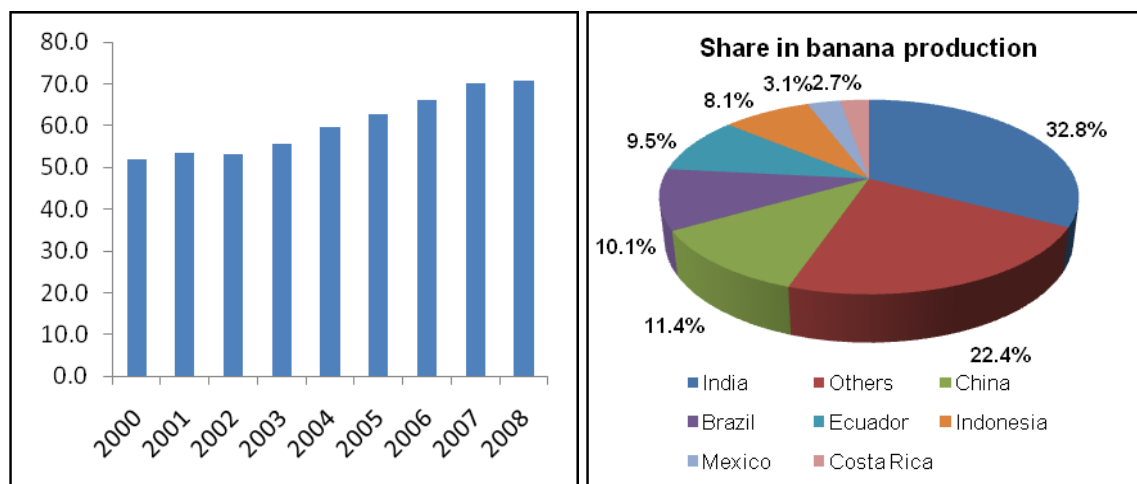

Source: FAO stats

6.3.56. Ecuador was the largest exporter of banana in 2007. The other major exporting countries in 2007 were Costa Rica, Colombia, Guatemala and Belgium. On the other end, Germany was the biggest importer of banana in 2007. The other major importing countries in 2007 were Belgium, Japan, Italy, France, Canada and China.

6.3.57. Philippines and Japan are the major banana fibre producing countries for large scale manufacturing of textile items made from banana fibre. Philippines is also exporting huge quantity of ready made garments manufactured from banana fibre to Japan, Singapore, Taiwan and all far East Asian countries. In India, banana fibre is primarily used in cottage industry present in Southern India.

Present status in India

6.3.58. India is the biggest producer of banana across the globe. The following table depicts the state wise banana cultivation belts.

Exhibit 6.3.17: State wise banana cultivation belts in India	
State	Banana growing belts
Andhra Pradesh	East Godavari, West Godavari, Kurnool, Cuddapah
Assam	Goalpara, Nagaon, Sonitpur, foothills of Garo hills
Gujarat	Surat, Vadodara, Anand, Kheda, Junagadh, Narmada, Bharuch
Jharkhand	Ranchi, Sahebganj
Karnataka	Bangalore, Chitradurga, Shioroga, Hassan, Chikka Mangloor
Kerala	Thiruvananthapuram, Kollam, Pathanamthitta, Alappuzha, Kottayam, Idukki, Emakulam, Thrissur, Palakkad, Malappuram, Kozhikode, Wynadu, Kannur, Kasargod
Madhya Pradesh	Khandwa, Badwani, Khargaon, Dhar
Maharashtra	Jalgaon, Ahmednagar, Buldhana, Pune, Wardha, Dhule, Nanded, Parbani, Nandurbar, Satara, Sangli, Osmanabad, Buldhana, Akola, Yeothmal, Amravati, Thane, Kulara, Alibag
Orissa	Ganjam, Puri, Khurda, Gajpati, Cuttack, Dhenkanal, Angul, Sundargarh, Sambalpur, Bargarh, Deogarh, Koraput, Keonjhar, Raygada, Mayurbhanj
Tamil Nadu	Thoothukudi, Tiruchirapalli, Coimbatore, Tirunelveli, Karur, Erode, Kanniyakumari
West Bengal	Hooghly, Nadia, North 24 Parganas

6.3.59. India produced 23.2 million tonnes of banana with a productivity of 35.9 tonnes per hectare in FY08.

Exhibit 6.3.18: Indian banana production and yield

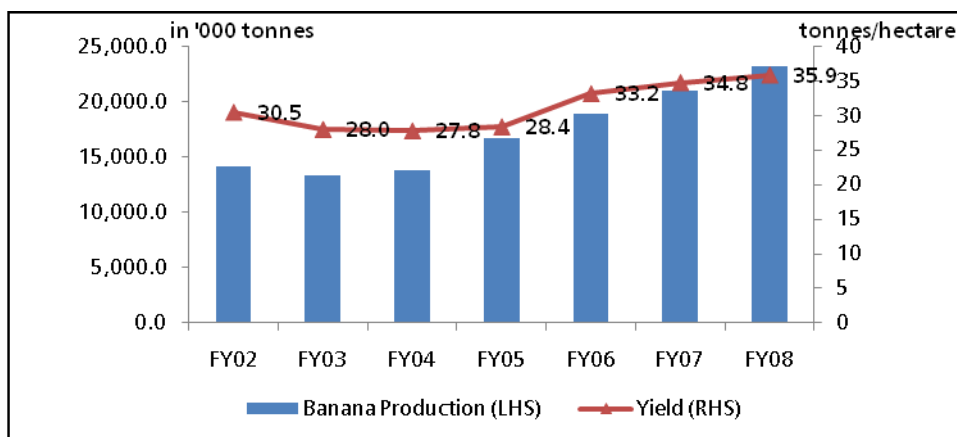

Source: indiastat.com



Exhibit 6.3.19: Banana production in selected Indian states in FY08			
States	Area ('000 Hectares)	Production ('000 Tonnes)	Yield (tonne/hectare)
Andhra Pradesh	53.23	1,543.8	29.0
Arunachal Pradesh	4.4	13.8	3.1
Assam	44	607.0	13.8
Bihar	17.9	233.6	13.1
Chhattisgarh	0.6	20.7	34.5
Goa	2.4	23.5	9.8
Gujarat	46.3	1,979.3	42.7
Himachal Pradesh	14.4	130.9	9.1
Karnataka	44.8	743.6	16.6
Kerala	59.3	439.8	7.4
Madhya Pradesh	7.46	568.8	76.2
Maharashtra	71	5,267.0	74.2
Manipur	9.4	120.4	12.8
Meghalaya	6.4	72.2	11.3
Mizoram	3.3	8.1	2.5
Nagaland	1	5.2	5.2
Orissa	22.2	284.8	12.8
Tamil Nadu	112.79	5,384.8	47.7
Tripura	7.3	95.3	13.1
Uttar Pradesh	2	77.7	38.9
Andaman & Nicobar Islands	1.9	15.6	8.2
Pondicherry	0.3	10.5	35.0
Lakshdweep	0.1	0.4	4.0

Source: indiastat.com



Fiscal structure

6.3.60. India is hardly present in international trade of banana crop.

Exhibit 6.3.20: Customs duty						
HS code	Item	Basic duty	CVD Ad. Val.	Education Cess @ 3%	Special Addl. CVD @ 4%	Total Duty Ad. Val.
53031090*	Other textile bast fibre	10.0	0.0	0.3	4.41	14.71

Source: www.infodriveindia.com

Issues related to technology, R&D, storage and etc.

6.3.61. Application of banana fibre for manufacturing textiles is a new concept in India. In India, only 10% of the banana waste (Pseudo stems) is used for extracting the fibre, rest is wasted. There is no standard way to extract the banana fibres in the country resulting in irregular demand supply situation, which finally leads to higher prices of banana fibres against other natural fibres for end users in the country.

Exhibit 6.3.21: Banana fibre prices vis-à-vis other natural fibre prices in India	
Natural fibres	Prices (US\$/kg)
Banana	0.43-0.81
Hemp	0.15-0.60
Kenaf	0.15-0.30
Flax	0.15-0.21

Source: *Journal of Engineered Fibers and Fabrics-Volume 3, Issue 2—2008*

6.3.62. The main reason behind under-utilization of banana fibre is the lack of sufficient scientific data on this fibre, except information regarding its chemical constituents. In India, banana fibre is primarily extracted manually. The manual extraction process causes low yield and high labor cost as this type of manual process needs skilled labor. Machine extraction process has following distinct advantages over manual extraction process.

- Reduced level of drudgery.
- It is user friendly, safer, cleaner and economic process. An unskilled worker can also operate the machine.
- It gives better quality fibre in terms of length and softness, strength & color.
- It increases fibre production by almost 50% to approximately 30 kg per day against manual process.

- 6.3.63. Presently, waste banana stems pose problem of disposal and are available almost free of cost in Central and South Gujarat. In recent past India has developed 'Banana Fibre Separator Machine'. This machine produces silk grade fibre from banana agricultural waste. The silk grade fibre is widely used by handicrafts and textile industry.

Applications and market potential

Usages

- 6.3.64. Banana fibre is used for manufacturing doormats, carpets, yarn, rope, geotextiles, luggage carriers and interior decorative items. In recent past, banana fibre has also been recognized for manufacturing high quality apparel garments and home furnishings due to increasing environmental awareness and growing importance of eco-friendly fabrics. Banana fibre is being used for making traditional dresses like kimono, and kamishimo in Japan since the Edo period (1600-1868). Banana fibre is also used to make fine cushion covers, neckties, bags, table cloths, curtains and other things. Rugs made from banana silk yarn fibres are also very popular world wide.

Market Potential

- 6.3.65. Banana fibre can be easily blended with cotton fibre or other synthetic fibres to produce blended fabric & textiles. Currently, it is mainly used by cottage industry in Southern India. Banana Fibre also finds use in high quality security/ currency paper, packing cloth for agriculture produce, ships towing ropes, wet drilling cables and others. Banana fibre has the potential to partially replace the consumption of cotton and jute fibre in India. It can be exported to far-east Asian and South Asian countries like Singapore, Taiwan, Japan, Thailand, Sri Lanka and Malaysia.

PHILIPPINES - BRIEF PROFILE OF ABACA FIBRE

- 6.3.66. Abaca plant (*Musa textiles*) is indigenous to Philippines. Abaca fibre is commercially known as 'Manila hemp'. Philippines remains the world's largest abaca fibre producer and supplies approximately 85% of total abaca fibre requirement.
- 6.3.67. Abaca was introduced in Philippines during Spanish time as clothing material. It is primarily cultivated in upland and interior parts of the country. The following table depicts the different varieties recommended for various regions of the country.



Exhibit 6.3.22: Different varieties recommended for various regions of the country

Growing regions	Varieties
Region V	Linawagan Puti, Linawagan pula, Sogmod, and Lausigon
Region VIII	Laylay, Inosa, Linawaan, Linlay, Putian, Laguis, Linlib, and Linino
Mindanao	Inosa, Tangongon, and Maguindanao

6.3.68. The national average fibre yield is 0.51 tonnes per hectare in 2006. It has superior tensile strength and enduring durability under water. It has more fibre than any other source making it more durable. Abaca fibre registered around 69,802 tonnes production with a cultivated area of 135,883 hectares in 2006. Eastern Visayas and Bicol are main producing regions of the country.

6.3.69. Philippines is manufacturing various products like cordage, ropes, twines, fibre crafts, furniture, garments, shawls, textiles cosmetics and skin care products, pulp and specialty paper from abaca fibres. The following diagrams depict the various conversion processes for different products.

Exhibit 6.3.23: Fibre to Fabrics (Handloom Process)



Exhibit 6.3.24: Fibre to Fabrics (Power loom Process)





Exhibit 6.3.25: Fibre to Pulp



Source: abacaphilippines.com

6.3.70. Abaca fibre is found in various grades like excellent (AD, EF, S2, S3), good (I, G, H), fair (JK, MI), coarse (L), residual (Y1, Y2, O, T, WS). Philippines is the largest exporter of abaca fibre and its products. Philippines generated around US\$ 80 million export revenue from Abaca.

Exhibit 6.3.26: Exports of abaca and its products from Philippines	
Items	Importing countries
Raw abaca fibre	United Kingdom (UK), United States (US), and Japan
Pulp	Germany, Japan, France, and US
Cordage, ropes, and twines	US, Singapore, Netherlands, UK and Canada
Yarns	Italy, UK, Japan, and US
Fabrics and fibre crafts	US, Japan, Spain, UK , and Hongkong

SISAL FIBRE

6.3.71. Sisal is a perennial plant. It can establish and grow in a variety of weather conditions including hot climates, including dry areas unsuitable for other crops. It is found on embankments, roadsides, bunds. Sisal plants aid in soil conservation and also in protection as hedge plantation.



Sisal fibre

- 6.3.72. Sisal fibre is creamy white in color and lustrous. It can measure up to 1 metre in length with a diameter of 200 to 400 microns. The sisal fibre is a coarse hard fibre which is strong, durable, and stretchable and does not absorb moisture easily, does not deteriorate in salt water and has affinity for dyestuff. Agricultural twine and ropes is still one of the largest markets for sisal fibre, while the highest fibre grades are used for manufacturing of rugs and home furnishing.
- 6.3.73. Sisal fibre has been traditionally used to make twines and ropes, due to its strengths, its property of stretchability, affinity for dyeing and resistance to weather conditions. However, in recent time it is being used for making specialty paper, filters, geotextiles, mattresses, carpets and wall coverings. It is also being used as reinforcement in plastic composite materials, particularly in automotive components and furniture. Another promising use is as a substitute for asbestos in brake pads. In addition, the by-products from sisal extraction can be used in bio-gas, pharmaceutical ingredients and building materials.
- 6.3.74. Usage of sisal fibre according to its grades is:
- The higher grade fibre after treatment is converted into yarns and used by the carpet industry
 - The medium grade is used for making ropes, balers and binders twine, which are utilized for agricultural, general and industrial use.
 - The lower grade has a high content of cellulose and hemicelluloses and is processed by the paper industry.
- 6.3.75. The fibre is also used for non-woven matting, brushing and roving. Sisal fibre can also be used as a replacement for silk fibre. The waste generated during decortication, which includes sisal juice, crushed tissue and fragments of leaves can be used as fertilizer, animal feed or also processed to make hand-made paper.

International scenario – sisal fibre

- 6.3.76. Global production of sisal is estimated to be around 0.3 million tonnes²⁷ (per year average over the recent years). Sisal fibre accounts for around 1.0% of the production of natural fibres in volume terms and around 0.2% in terms of value. The global slowdown has adversely impacted the demand for sisal fibre and also led to a reduction in prices.

²⁷ Common fund for commodities – Proceedings of the symposium on natural fibres, October 2008



6.3.77. Brazil, China, Tanzania and Kenya are the major producers of sisal in the world. Production patterns differ between countries. In Tanzania and Kenya sisal is predominantly a plantation crop, while production in Brazil is largely small-scale.

Exhibit 6.3.27: Global sisal production

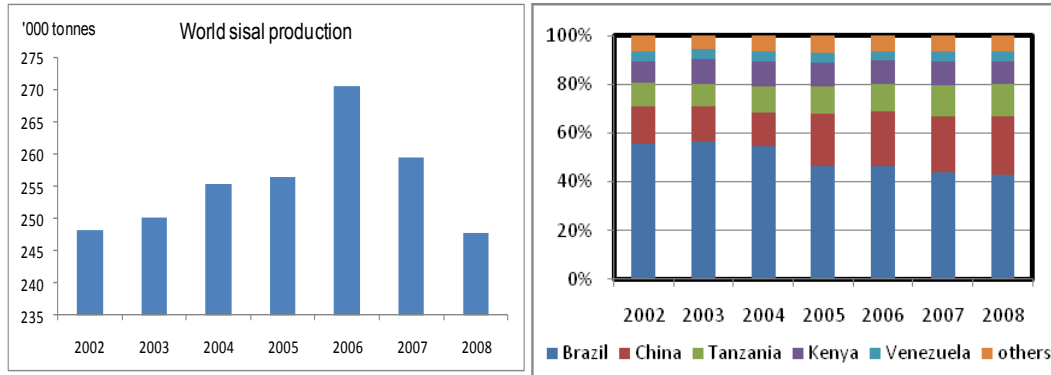

Source: FAO Stats

6.3.78. Brazil, Kenya, Tanzania and Madagascar are the major exporters of sisal fibre in the world. Exports account for around 80% of the total production of sisal fibre in Kenya and Madagascar. In terms of quantity, Brazil is the largest exporter of sisal fibre in the world with volumes of around 52,600 tonnes. Exports from Brazil dropped drastically to 27,100 tonnes in 2008. Exports and trade markets for sisal has witnessed a decline with the availability of cheaper synthetic substitutes (polypropylene and polyester) and lack of market development initiatives on part of the sisal industry. However, with petroleum prices, major feedstock for the synthetic substitutes increasing and growing environmental consciousness, the situation is witnessing a change.

Exhibit 6.3.28: Exports of sisal fibre

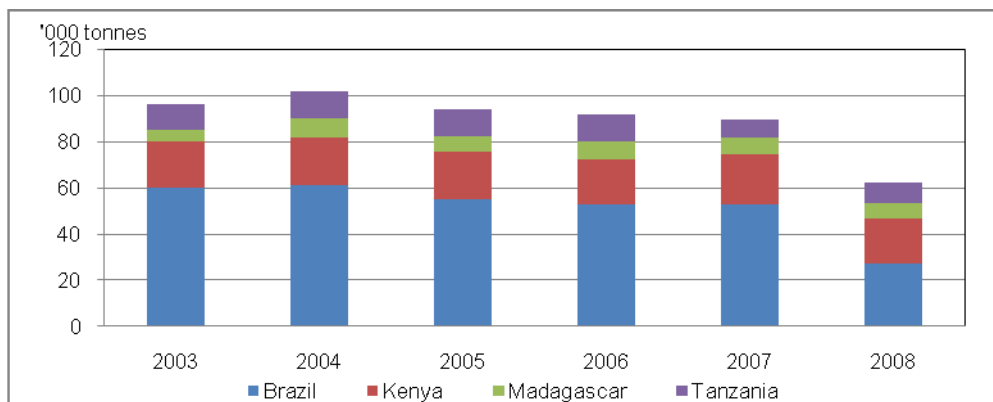

Source: FAO stats

6.3.79. China dominates the market for imports of sisal fibre currently. Sisal fibre imports by China has increased steadily in recent years and in 2006, imports by China accounted for around 46% of total world imports of sisal fibre.

Present status in India

- 6.3.80. Sisal is mainly grown in arid and semi-arid regions of Andhra Pradesh, Bihar, Orissa, Karnataka, Maharashtra and West Bengal. About 275 species are distributed in tropical regions of India. A number of programmes undertaken by government and government agencies (different states) have led to the cultivation of sisal cultivation in these states. India's imports of sisal fibre rose from 800 tonnes in 2001 to 1,800 tonnes in 2005. However in dropped drastically to 900 tonnes in 2006.²⁸
- 6.3.81. Sisal cultivation, fibre extraction and product making is a labor intensive process, with use of very low level of technology. The sector is largely unorganized. The average yield of sisal in our country is very poor, due to lack of proper care and attention to the crop.

Exhibit 6.3.29: Sisal in India	
States	Districts
Karnataka	Chamrajnagar
Tamil Nadu	Vellore
Uttarkhand	Kumaon, Kotdwar, Kolhupani, Dehradun
Madhya Pradesh	Durg, Bhopal
Maharashtra	Ahmednagar
West Bengal	Midnapur (E)
Jammu & Kashmir	Bhalwal, Jammu, Ratnapur, Sarara, Kathuwa, Kathua

Source: *List of potential hubs – Ministry of Textiles, www.indianhandicrafts.nic.in*

Issues related to technology, R&D, storage, others

- 6.3.82. Some of the problems associated with sisal are the long time taken for cultivation; it takes on an average around 4 years for a plant to be ready for harvesting (leaves). Pace of introduction of new products has been relatively very slow for the industry. More research and development activity needs to be undertaken to design new products that can meet the competition put up by products made from synthetic substitutes.
- 6.3.83. There is a greater need for marketing activities for creating awareness of sisal fibre and products made from sisal fibre. In addition, newer products need to be designed from sisal fibre.

²⁸ FAO Statistics



Market status and potential

- 6.3.84. The sisal sector in India is largely unorganized. In countries like Tanzania, which is the second largest producer of sisal in the world, sisal industry is privatized, largely with businessmen, investors and development agencies.

Exhibit 6.3.30: Duty on sisal fibre						
HS code	Item	Basic duty	CVD Ad. Val.	Education Cess @ 3%	Special Addl. CVD @ 4%	Total Duty Ad. Val.
53041010*	Sisal fibre	12.5	8.16		4.89	26.55

Note * - As of March 2006

Source: www.infodriveindia.com

- 6.3.85. Sisal fibre attracts an excise duty of 8% (cenvat). In addition, there is a cess of 2%. (as of March 2006)

Process of extraction

- 6.3.86. A sisal plant generally yields 220-250 leaves over a period of 6-9 years. Sisal fibre represents only around 3-4% of weight of the sisal leaf. Sisal fibre can be extracted through various ways including retting process, mechanical process (decorticator machine) and chemical process. Traditionally, fibre was extracted from sisal plant through retting process, which takes around 15-21 days for a single cycle of extraction. The disadvantages of this process are it is water intensive, unhygienic and not eco-friendly and also degrades the quality of the fibre.
- 6.3.87. The mechanical extraction of sisal fibre is carried out with the help of a raspador machine (developed by RRL, Bhopal). It is a semi-automatic machine suitable for small scale operations. In the process of making sisal fibre from decortications, the leaves are crushed so that only the fibre remains. Followed by extraction, the fibre is washed and dried. They are dried either in the sun or by hot air. The quality of the fibre depends on the moisture content in the fibre, hence drying forms an important process of fibre extraction. The dried fibre is then beaten to remove undesired particles. The dried fibre undergoes carding process; a mechanical process that breaks locks and unorganized clumps of fibre into individual fibres. The carding process, at times is either done manually through the use of comb, scissor, etc or machined combed and sorted into various grades.
- 6.3.88. In Africa, large centrally-located decorticating machines are used, with running water employed to wash away waste. In Brazil, where the drier climate limits water supply, portable scrapers are used.



- 6.3.89. As the fibre is coarse and strong it is not very suitable for use in textiles and fabrics. There are also problems associated with spinning the fibre into fabric. A high degree of beating and pulping aids the process of converting the fibre into fabric. Sisal fibre is also used along with silk. Due to the huge amount of work that is involved in processing sisal into fabric, the value of the fabric is very high.
- 6.3.90. The process used to extract sisal has witnessed little change over the years. There is a greater need to improve production and processing technologies which would also enable optimal utilisation of the other waste generated during fibre extraction. Machines which are safer and more efficient need to be designed.

Potential demand for sisal fibre

- 6.3.91. Availability of cheaper synthetic substitutes is hampering the demand for sisal fibres. However, the sharp rise in petroleum prices along with growing environmental awareness is leading to a revival for products made from natural fibres at the global level. Geotextiles is an emerging sector in India, and this segment holds huge potential for sisal fibres. In addition, automotive application also holds huge potential for sisal fibre.

CASE STUDY – SISAL INDUSTRY IN KENYA

- 6.3.92. The Kenyan sisal industry was born in 1907, when the first sisal plantation was established. By 1914, Kenya was exporting sisal fibre to Europe. Rising demand for sisal harvest backed by increased demand for baler twine led to rapid growth of the sisal industry over the next 50 years. By 1954 a spinning factory was opened to process twine, ropes, gunny bags and later sisal carpets and mats to cater to the domestic and export market. With the rapid growth in the industry, the need for research and development activities to support the industry was felt. Consequently the High Level Sisal Research Station was opened at Thika in 1937. This research station aided the growth of the sisal industry in the country. It developed superior varieties, improved agronomic, management and processing practices which provided the foundation of the sisal industry.
- 6.3.93. Recognizing the growing importance of sisal in the country's economy, the **Kenya Sisal Board** was formed in 1946. The mission of the board was to regulate the industry and cater to the welfare and promotion of the industry. In the subsequent years till 1980, the industry suffered due to invention and rapid growth of the man-made fibres industry. Demand for sisal fibre was severely affected during the period 1960s to late 1980s. The trend witnessed a reversal in 1990s with the entry of new products in the market and newer markets. Application of improved production and processing techniques further accelerated the rise in demand for sisal fibre.
- 6.3.94. The Kenyan sisal industry which comprises of producers, marketing agents and spinners is regulated by the Sisal Board of Kenya which falls under the Ministry of Agriculture. The Kenya Sisal Board also

facilitates the marketing of sisal in both the local and export markets. The marketing agents are licensed and are registered by Kenya Sisal Board.

Legal & regulatory framework for sisal industry in Kenya

- Sector regulation

The Sisal Board of Kenya is a single regulatory body that ensures investors have a single source of investment advice for the sector. It also facilitates registration of players in the sector.

- The farmers have formed the Kenya Sisal Growers' and Employers Association to articulate issues concerning the industry
- Exports from the country enjoy preferential access to world markets under a number of special access and duty reduction programmes.
- The Kenyan High Level Sisal Research Station provides industry research activities in areas such as improved varieties, farming practices and processing techniques.
- The Kenyan also provides a number of investor friendly arrangements which includes
 - Export Processing Zones program which offers attractive incentives to export-oriented investors and the authority to provide one-stop-shop service for facilitation and aftercare.
 - The Investment Promotion Centre to promote investment in Kenya, including the Manufacturing Under Bond (MUB) program
 - The Tax Remission for Export Office (TREO), a program for intermittent imports for export production
 - Investment and capital allowances
 - Double taxation, bilateral investment and trade agreements.

PINEAPPLE FIBRE

Pineapple

- 6.3.95. Pineapple is the common name for an edible tropical plant, which belongs to the family of Bromelia. While most Bromeliads grow on trees, the pineapple is a ground fruit. This plant is native to the southern part of Brazil and Paraguay. The quality of the pineapple which is used for extraction of fibre is different from what is grown as a fruit. The leaves of a fruit bearing plant also yield fibre; however,

they do not yield good quality fibre. Pineapple plants, with long leaves, specially cultivated for its fibre give the finest quality of fibre.

Pineapple fibre

6.3.96. Pineapple fibre is more delicate in texture than any other vegetable fibres. It is white, creamy and lustrous as silk fibre and is 10 times as coarse as cotton, although it is fine (as fine quality jute) with well separated filaments. The fibre can easily retain dyes. The bundle strength of the pineapple leaf fibre diminishes on wetting; however the strength of the yarn increases. A mature plant has about 40 leaves, with each leaf being 1-3 inches broad and ranging in length from 2-5 feet. The average plants per hectare is around 53,000 plants, which can yield 96 tonnes of fresh leaves. On an average one tone of fresh leaves can yield 25kg of fibres, thus total fibre extraction can be around 2 tonnes of fibre per hectare.

6.3.97. Some of the characteristics of the pineapple fibre are:

- It is very hygroscopic
- It has a high cellulose content
- It has a low microfibrillar angle
- Fibre bundle strength decrease by 50% when wet
- Yarn strength increase by about 50% when wet
- Difficulties in dye penetration due to high coarseness

6.3.98. The leaves are a major waste of pineapple cultivation and include fibrous and non fibrous residues. The fibrous residues represent about 54.3% by weight.

The properties of the fabrics made from pineapple leaf fibre are easy to print and dye, sweat absorbent and breathable, hard and not wrinkling, has good antibacterial and deodorization performances.

Usage

6.3.99. Handicraft artisans in Philippines have been using pineapple leaves for long to produce cloth. Pineapple silk is considered the queen of Philippine fabrics and is considered the fabric of choice of the Philippine elite. Pineapple fibre is sometimes combined with silk or polyester to create a textile fabric, which is lightweight, has an elegant appearance similar to linen and easy to care. The pineapple threads have also been used for long in India and China for lines and threads and as an adulterant in silk. Pineapple fibre is also used for table linens, bags, mats and other clothing items, where lightweight and stiff fabric is needed. The characteristics of the fabric made from pineapple fibre make it ideal for high grade suits, shirts, divided skirt, decorative fabrics and so on.



International scenario

- 6.3.100. Global production of pineapple was around 19 million tonnes in 2008. Production of pineapple rose from 16.6 million tonnes in 2004 to around 21 million tonnes in 2007. Production declined in 2008. Pineapple plants are largely grown in tropical America, Far-East Asian countries and Africa. Brazil and Thailand are the largest producers of pineapple fibres in the world. Brazil accounted for around 13%, while Thailand and Philippines accounted for around 12% of global pineapple production during 2008. In Philippines and Taiwan, the pineapple plant is largely used as a source of fibre. In India, also the pineapple plant is used as a source of fibre.
- 6.3.101. Cloth made from pineapple fibre in Philippines is exported to various parts of the world, most particularly to North America and Europe.

Exhibit 6.3.31: Global Pineapple production

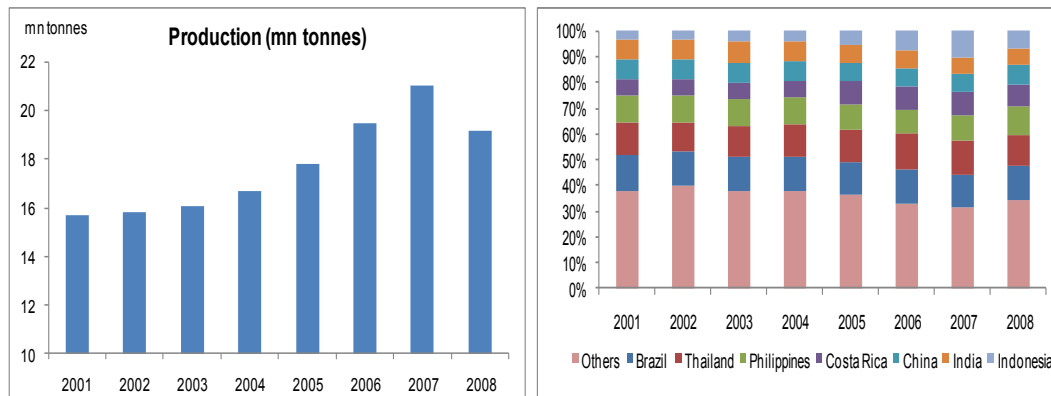

Source: FAO Stats

- 6.3.102. Costa Rica is the largest exporter of pineapples. In 2006 & 2007, exports of pineapple by Costa Rica accounted for almost 48% of the total exports of pineapples in the world. The other major exporters of pineapples in the world are Philippines and Belgium, accounting for around 9% each of pineapple exports in the world.
- 6.3.103. The major importers of pineapples in the world are Belgium, Netherlands, Germany, Japan and Italy.



Exhibit 6.3.32: Exports of Pineapples

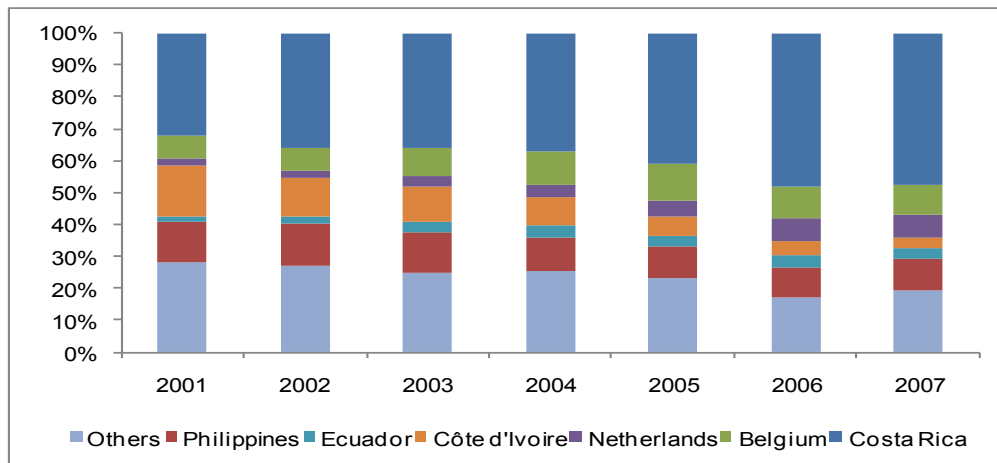

Source: FAO stats

6.3.104. Pineapple fibre finds different uses across the various parts of the world. The Chinese (Kwantung Province, Island of Hainan) weave the fibre into coarse textiles, which resembles grass cloth. In India, the thread is used by shoemakers. In West Africa, the thread is used in the jewellery sector for stringing jewels and also for making caps worn by tribal chiefs. The people of Guam make fine casting nets by hand-twisting the fibre; also use it for wrapping or sewing cigars. In Philippines, they use it for making cloth.

Present status in India

6.3.105. Pineapple also offers itself to fibre extraction and value addition into fabrics of high quality. Pineapple cultivation in India is spread across 80,000 hectares of land and is the sixth largest producer of pineapples in the world. In FY08, India produced 1.2 million tonnes of pineapple and the major pineapple producing states in India are West Bengal, Assam, Karnataka, Bihar, Tripura and Kerala.

6.3.106. Given the average potential of around 2 million tonnes of fibre per hectare, potential for total fibre production in India is around 160,000 metric tonnes.

Exhibit 6.3.33: Share of States in Pineapple production

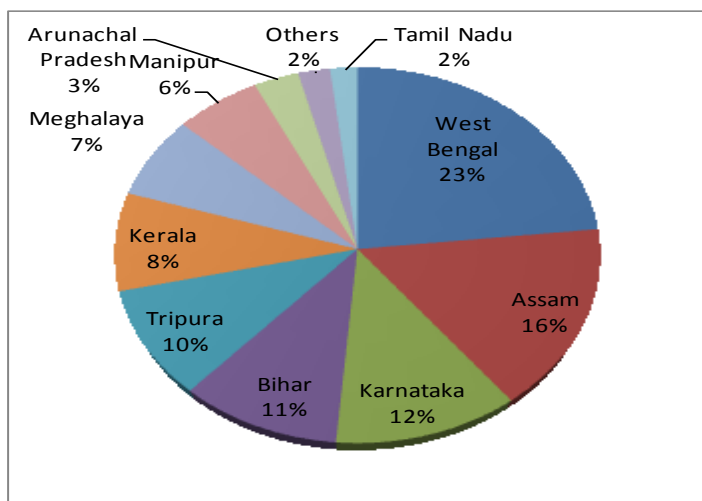

Source: National Horticulture Board

Exhibit 6.3.34: State-wise Pineapple growing belts	
State	Regions
Karnataka	Shimoga, North & South Kannada , Chickmagalur
Kerala	Ernakulum
Nagaland	Kohima, Zunheboto
West Bengal	North Dinajpur, Darjeeling, Jalpaiguri
Assam	Nagaon, Kamrup, Karbi Anglong
Bihar	
Manipur	Thoubal, Churachandpur, Imphal East
Meghalaya	RiBhoi, East Khasi, Garo Hills

Source: National Horticulture Board

Issues related to technology, R&D, storage, others

- 6.3.107. The manual process of extracting fibre is very laborious and also there tends to be a lot of wastage. In addition, the time taken is much lesser.
- 6.3.108. One of the largest hurdles for pineapple fabric in India is the great need for marketing. For a pineapple fibre extraction plant to be successful, it is necessary to have a continuous flow of large orders.

However, given the lack of marketing support, large orders are difficult to obtain. Other countries, such as Japan and Philippines have been successful in getting large orders for pineapple fabric.

Fiscal structure

Exhibit 6.3.35: Customs duty on pineapple fibre						
HS code	Item	Basic duty	CVD Ad. Val.	Educational Cess @ 3%	Special Addl. CVD @ 4%	Total Duty Ad. Val.
53031090	Other textile fibres(excluding flax, true hemp, and ramie), raw or processed	10.0		0.3	4.41	14.71

Source: www.infodriveindia.com

6.3.109. There is no incidence of excise duty on pineapple fibre.

Process of extraction

6.3.110. The process of fibre extraction from the pineapple leaf can be done either manually or with the aid of machines. The manual process involves stripping off the fibre from the retted leaf. In this method a lot of fibre is lost and the entire process is also very laborious. With this process, the yield is around 2-3% of dry fibre, which is about 20-27 kg of dry fibre from 1 tonne of pineapple leaf. The process which uses machines is slower than the manual process; however it facilitates the further production process.

6.3.111. The manual process involves up to 30 people from the beginning to the end of the process. Fibres of the leaf are scrapped by means of a broken plate or coconut shell and a fast scraper can extract fibre from over 500 leaves per day after which the fibres are washed and dried in the open air.

Exhibit 6.3.36: Process of extraction of pineapple fibre





- 6.3.112. After drying, the fibres are waxed to remove the entanglements and the fibres are knotted. During the knotting process, each fibre is extracted singly from the bunch and knotted end to end to form a long continuous strand. The fibre is then sent for warping and weaving.
- 6.3.113. In the mechanical process, the green leaf is crushed in a raspador machine. The soft green parts of the leaves are crushed and washed in water and the thread is taken out. The thread is then brushed with a comb and fine threads are separated from the spongy ones. The last step is knotting of the threads by hand and spinning the threads with the help of a charkha. This final product is one thread, which can be used for preparation of fabric and clothes. The longer threads are used for making fabric, while the smaller ones can be use for making carpets, sponge seats, and ropes, amongst others.
- 6.3.114. The South India Textile Research Association (SITRA) has developed a model for extracting pineapple fibre. The plant comprises of the decorticating machine, fibre cleaner, carding machine and a single ply machine besides a rope-making machine. The plant is capable of yielding 35 kg of leaf-fibre per 8 hour shift.

Potential demand

- 6.3.115. There are around 80,000 hectares of land under pineapple cultivation and given the average yield of around 2 tonnes of fibre per hectare, the total potential for production of pineapple fibre in the country is 160,000 tonnes.
- 6.3.116. There is huge potential for pineapple fabric, given its diverse uses and eco-friendly properties. The wrap and weft of the fabric made from pineapple fibre makes it ideal for furnishings.

6.4. RECOMMENDATIONS OF THE SUB-GROUP FOR OTHER NATURAL FIBRES

6.4.1. The "Natural Fibre Policy" needs to accord special attention for promotion of other natural fibres, as they are vitally important for the following reasons:

- Large global market and potential to provide farm and off-farm based employment to large populations in rural, semi urban and urban areas.
- Utilizes so-called 'waste' items to generate wealth; hence, provides additional avenue for livelihood generation.
- Allows for 'Green Economy', while also adding to the green cover of the country.
- Potential to off-set the negative impact of industrial processes and carbon emissions.
- Aids the country in achieving its objectives under the United Nations (UN)'s 'Millennium Development Goals'

6.4.2. Therefore, the major policy intervention recommendations suggested by the sub-group on Other Natural Fibres are as follows:

SELECTION OF FIVE KEY FIBRES FOR DEVELOPMENT

6.4.3. The sub-group is in consensus that policy intervention in the first phase ought to be limited to five major natural fibres, viz., Banana fibre, pineapple fibre, flax, Sisal, and Hemp/Nettle. The rationale for the above choice of fibres is as follows:

Use in textile segment: The primary criterion for the selection is the fibres should be used in the textile industry (convertibility into textiles).

Easy availability: These fibres/plants are cultivated in India in fairly abundant quantity, and therefore are relatively easier to exploit for commercial purpose. Examples- Banana, Pineapple

High growth potential: The selected fibres are currently being imported into India in a reasonably significant amount. Thus, this signifies domestic demand for these fibres, and the replacement of this high imports is an opportunity. Examples- Flax and Sisal.

Neutrality to other crops: These crops are already being largely grown, and thus do not pose a threat to acreage under the other crops and will use existing biomass.

State participation: Active state participation is already present in these selected fibres, with considerable institutional support also available, thus allowing policy intervention to yield maximum benefit within a short period.

Existing human resource: Traditional knowledge and existing human resource are already available for chosen fibres at local levels.

RECOMMENDATION FOR FURTHER STUDY

- 6.4.4. As the majority of the potential fibre yielding plants such as screw pine, water-hyacinth, ramie, palm leaf and korai grass are not taken in the scope of this sub-group. These fibres are available in India and have varied usage across different product categories such as textiles, handicrafts, utility items and others. The sub-group hence, recommends that another focus study may be taken up on these fibres.
- 6.4.5. Screw pine is being currently commercially utilized in different states of the country, which include Orissa, Tamil Nadu, Kerala, Andhra Pradesh, West Bengal and Uttar Pradesh. Items made from screw pine leaves include mats, boxes, hats, bags, amongst others.
- 6.4.6. In India, water hyacinth is used for manufacturing paper (under cottage industry), baskets, and mats. It is used as animal fodder and used as vermin-compost in some parts of the country. Globally it finds diverse applications. Yarn, rope made of the fibre of water hyacinth is used to make furniture in Bangladesh and baskets in the Philippines. The fibre is also utilized for making hard-wearing sandals in Thailand. Other items made from this fibre include napkin rings, chair seats and placemats.
- 6.4.7. Palm leaf fibre is used to make ropes, mats, brushes, fish nets, brooms, amongst others. Ramie plant is grown largely for its fibre in China, Lao PDR and the Philippines. The yarn produced from ramie fibre is suitable for a wide range of garments. It is also suitable for making twine, rope and nets and is usually blended with other textile fibres. Korai grass is used to make different utility products such as bags, bins, boxes, amongst others.
- 6.4.8. In order to promote the above mentioned fibres in the country, this sub-group suggests that a study may be taken up to devise promotional mechanism for the above-mentioned fibres.

CENSUS ON OTHER NATURAL FIBRES

- 6.4.9. India has a wide and rich variety of other natural fibres. However, data and information on the same is not readily available. Given the huge potential these other natural fibres hold in terms of demand and their contribution to the overall economic growth of the country, the sub-group recommends a national-level census to gather exhaustive information on other natural fibres in India. The census would aim to gather data and information on the following for each of the other natural fibres found in India:
- Geographic areas/regions i.e. other natural fibre availability
 - Area under cultivation.
 - Yield of the crop as a whole and yield of fibre
 - Quantification of fibre in volume terms

- Process and technology adopted to produce the fibre
- Types of tools / machinery employed (level of mechanization)
- Price of fibre
- Current utilisation / Products made from the fibre (Textiles/handicraft items/utility items/others)
- End-markets for the fibre
- Distribution network/channels for the fibre/products made from the fibre
- Potential for the fibre and products

RECOMMENDATIONS/POLICY INTERVENTIONS FOR THE SELECTED FIVE FIBRES

- 6.4.10. The recommendations/policy interventions suggested by the sub-group with respect to the selected five fibres are mentioned below.

Proposing a 'Focus Fibre Focus State' Approach

- 6.4.11. To achieve the desired results for each of the selected fibre, the sub-group proposes a Focus Fibre, Focus State (FFFS) approach for implementation. This will enable promotion of the selected fibres in a localized format, and allow the development of critical mass for these focus fibres. This also allows for most efficient utilization of funds, easy monitoring of the progress made and ensures better rate of return on investments made. The leading fibre-producing states for each of the fibres were identified and based on intensity of cultivation (area of the fibre to total area), the states for each fibre was short listed.

The chosen states for the selected fibres under the 'Focus Fibre Focus State Approach' is as follows:

FFFS Selection

- **Banana: *Tamil Nadu***
- **Pineapple: *Tripura***
- **Sisal: *Orissa***
- **Hemp/Nettle: *Uttarakhand***
- **Flax: *Madhya Pradesh***

- 6.4.12. The FFFS approach is specific for each selected fibre, as the selected fibres/plants are either already cultivated in large quantities (Banana and Pineapple) or are available, but not commercially exploited or needs to be promoted (Sisal, Flax, Hemp / Nettle).

- 6.4.13. Based on the above implications, the sub-group divided these five selected fibres into two distinct groups for undertaking measures for their respective holistic development, the groups are:

1) **Group I** (Banana and Pineapple)



2) **Group II** (Sisal, Hemp / Nettle and Flax)

The development approach and recommendations for the two different groups are as follows:

Exhibit 6.4.1: Group I Fibres	
Group I	<p>Considering the abundant availability of Group I Fibres/plants (wealth from waste) in the country, the following fibres are grouped together.</p> <p>Banana: Harvested area under banana was approximately 6.5 lakh hectares in India in 2008. Pseudo-stem alone would have accounted for approximately 28 million tonnes. Out of 28 million tonnes pseudo-stem, the yield of banana fibre could be around 2.2 million tonnes every year.</p> <p>Total world production of Abaca fibre, which belongs to the same family as Banana (Banana – Musa family) was around 86 thousand tonnes in 2004 and exports of the fibres was worth US\$ 79.2 million.</p> <p>Pineapple: Pineapple has total acreage of around 81,900 hectares in 2008 and India is the sixth largest producer of pineapple in the world. India has the potential to produce around 0.16 million tonnes of pineapple fibre based on an average potential yield of around 2 metric tonnes of fibre per hectare.</p>

Exhibit 6.4.2: Group II fibres	
Group II	<p>Considering the growing interest in sisal, hemp and flax, due to their various applications and potential at national as well as international level, the following fibres are grouped together.</p> <p>Sisal: World production of sisal and agave fibre, <i>henequen</i>, is estimated at around 3 lakhs tonnes, valued at US \$75 million. In terms of value, India was the 2nd largest importer and 5th largest exporter of sisal in the world in 2007. India exported 341 metric tonnes of sisal valued US\$ 1.33 million and imported sisal of 1,951 metric tonnes valued US\$ 2.33 million in 2007. Agave got completely naturalized throughout the country, particularly in Chhattisgarh, Madhya Pradesh, Andhra Pradesh & Karnataka, Tamil Nadu and also other states.</p> <p>Hemp/Nettle: The global production of hemp fibre is 0.1 million tonnes and large promotion is happening in China, EU and Canada considering the future growth.</p> <p>Flax: The flax fibre production in the world is around 8.23 lakh tonnes and export value of flax fibre and tow of first 20 exporting countries was US\$ 381 million in 2007. India has a cultivation area of 4,36,800 hectares with possible yield of 1-1.5 metric tonnes per hectare.</p>

Immediate (Short Term) strategies for Group I

6.4.14. Considering the large availability and strong potential for future growth, the following is a three-pronged approach:

- Promoting and attracting industrial investments for mass consumption of raw materials to utilize the so-called waste materials into products (wealth) in order to generate additional income for the farmers. The sub-group recommends that the government provide capital subsidy of **50%** to the industrial investors as an incentive for setting up the industry to

consume natural fibres (other natural fibres as raw material). It also recommends that the government provide support for setting up feeder units for large industries for commercial feasible exploitation of natural fibres.

17. Research and Development into improved and efficient extraction and processing of fibres with low cost, appropriate technology, as well as yarn spinning techniques and technology, keeping overall global pricing as well as minimum wage issues in mind.
18. The sub-group recommends undertaking a 5-year pilot program under '**Cluster Approach**' to promote livelihood and economic development for each of the 2 fibres under the Group I at local levels. The pilot program would be carried out in 1 or 2 geographical areas in the focus state for each fibre. The rationale behind the pilot project would be to develop and replicate the best practices that can be replicated on pan-India basis. This would accelerate the income, employment opportunities and value addition at local levels.

Immediate (Short Term) strategy for Group II

6.4.15. Considering the potential of fibres taken under the Group II, the following are the approaches suggested by the sub-group.

19. Undertake research and development programmes on raw material resources (Sisal, Flax, Hemp /Nettle) for breeding of different varieties, standardization of nursery practices and fibre extraction techniques.
20. The sub-group recommends undertaking a 5-year pilot program for Group II Fibres, under **cluster approach**. The pilot program would be carried out in concentrated geographical area of each focus state for each fibre. The learnings of the pilot project shall form the basis for replication of interventions on pan-India basis.

Common Strategies for cluster approach for Group I & Group II fibres

6.4.16. Components of Cluster approach (Group I (Point No. 3) & II)

The various recommendations/suggestions of the sub-group under the cluster approach are:

- Awareness, sensitization and education on other natural fibres at all levels
- Mobilization of the communities by the pilot program carried out by implementation agency at the state level
- Promoting sustained and cooperative R&D activities for the entire cycle of fibre. This will include extraction, processing techniques, tools and machinery development, diversification of product ranges, value addition and industrial research for mass and commercial consumption, etc.

- To ensure the economic viability and commercial utilisation of waste generated during processing, (In case of sisal, only 4% of the entire raw material is used as a fibre and 96% is waste), the efforts should be directed towards exploring the possibility of converting the waste into bio-fuel, manure, bio-gas and electricity, organic pesticides, animal feed, etc. For instance, proportion of sisal fibre is only 4% of entire biomass. In the case of hemp/nettle and flax, nearly 72% of the waste can be converted into composites for its utilisation in automobiles, construction as alternate for glass fibres.
- Revisiting the rules and regulation and legal procedures pertaining to the growing, harvesting and licensing in environment sensitive areas.
- Standardisation and certification
- Networking with technical, resource and market agencies such as ICAR, ICFRI, RRL, CBRC, SITRA, CSIR, etc.

Other Interventions for development of Group I & II fibres

- 6.4.17. In addition to the above mentioned strategies, the sub-group recommends the following interventions for the development of Group I & II fibres.

Capacity building / training

- 6.4.18. The sub-group recommends arranging specialised technical and commercial training (short term and long term) with the help of international trainers from the countries such as Philippines, Indonesia, Thailand, China and others. Specialised and continuous training programmes should also be devised with enhanced financial limits to attract the best trainers.

Creation of necessary infrastructure

- 6.4.19. With an aim to create the necessary infrastructure for the promotion of the fibres, the sub-group recommends the following:
- To facilitate the creation of infrastructure facilities at the clusters especially, Common Facility Centres (CFCs), treatment and dyeing facilities, raw material banks, resource centre on pilot basis in the first phase ensuring efficient and standardized manufacturing process.
 - Development of feeding units for the supply of processed raw materials for the large industries in long run.
 - Conversion of waste arising from manufacturing process into value added composites.

Aggressive international marketing

6.4.20. The sub-group believes that aggressive marketing measures need to be undertaken for promotion of products made of other natural fibres and for the same recommends the following:

- Special International Marketing programme should be launched for 3 – 5 years.
- Identification/earmarking of most potential international markets.
- Special theme settings in the overseas shows to attract overseas buyers/ customers.
- Participation in international shows focussing on Other Natural Fibres.
- Thematic display at textile and apparel exhibitions.

Brand building & brand promotion

6.4.21. The sub-group understands that brand building and brand promotion are two important measures that need to be undertaken for promotion of products made from other natural fibres and for the same it recommends the following:

- Focus on brand building measures and promotion campaigns such as “Go Green” – "Green India", etc
- Launching an exclusive International Show on the Indian Natural Fibres and the Green Products
- Buy back arrangements – sourcing, facilities, and retailers across the globe to ensure consistent availability of raw material etc.
- Regular study and promotional tours.
- Promotional shops for exclusive Natural Fibre products at all the Indian Airports and Railways.

Fiscal measures

6.4.22. The sub-group recommends the following fiscal measures for other natural fibres.

- 100% exemption on custom & excise duties on the import of plant & machinery, consumables, embellishments on natural fibres for enhancing the quality.
- 50% capital subsidy for entrepreneurs promoting Other Natural Fibre based industries.
- Tax holidays for manufacturing and exporting units for 10 years
- Interest subsidy for establishments (like TUFS)

- Duty drawbacks on the finished products of natural fibres.

Enhancing competitiveness

6.4.23. To ensure competitiveness of Indian products made of other natural fibres, the sub-group recommends the following:

- Easy and hassle free availability of latest technology/ technology transfer as available in China, Indonesia, Vietnam, Thailand, Philippines, or other South East Asian countries.
- Time bound work plan for increasing the competitiveness of the fibre industry by attracting 'Foreign Direct Investments' (FDI) and 'Joint Venture' (JV) partners to help in improvement of technology and volume production.
- Information dissemination through various media such as print, electronic, etc to highlight the strengths of Other Natural Fibre in India and other technical inputs which can attract overseas companies to invest in India.
- Market oriented study tour to understand the technology, finishes, product development and other applicable marketing measures adopted by the producer countries.

Intermediate strategy (for 5 Years)

6.4.24. To accelerate the development of Group I and II fibres, this sub-group proposes a holistic approach under intermediate strategy for initial 5 years. This holistic approach includes development strategies, identification and transfer of best practices, implementation of program, documentation and standardization of practices gained in above mentioned immediate strategies which will further pave the way for the long term mission.

The institutional framework of the intermediate strategy (5 years) is as follows:

National Steering Committee

6.4.25. National Steering Committee will be formed under the Chairmanship of the Secretary, Ministry of Textiles, Government of India. The role of the national steering committee would be to oversee as well as provide direction and approve the Action Plans submitted by the 'Centre for Other Natural Fibres Development'. The National Steering Committee will meet once in a year.

The composition of the committee will be as follows.

Exhibit 6.4.3: National Steering Committee	
Secretary, Ministry of Textiles	Chairman
Secretary- Agriculture, Environment and Forests, Science and Technology, Rural Development, Small scale industries	Members
Representative of NABARD	Member
Representative of KVIC / KVIB	Member
Selected members of sub committee	Member
Technical Experts from production, processing, marketing and value addition	Member (s)
Chairman – Centre for Other Natural Fibre Development	Member Secretary

Centre for Other Natural Fibre Development

- 6.4.26. In order to provide the required push for the promotion of the sector, dedicated Centre titled '**Centre for Other Natural Fibres** Development' will be created under the Ministry of Textiles as a society under the 'Societies Act'. The centre will function under the guidance of the National Steering Committee. Its main function is to co-ordinate and facilitate the activities and liaison with working and existing stakeholders.
- 6.4.27. The membership of the Society will include an officer of the Ministry at a suitable designated level and the members of the board will consist of representatives from the focused states, EPCH, ICAR, CSIR, NGO and experts from the sector.
- 6.4.28. To implement the activities at state level, the respective state governments would be urged to establish dedicated fibre development centres. The state level centres would be linked to the 'Centre for Other Natural Fibres Development'.

Working Groups

- 6.4.29. Working groups for each of the sectors viz, research, technology development, plantation, diversification / value addition and marketing will be constituted under the Centre for other Natural Fibres" The centre will coordinate the activities and functioning of the working groups. The working groups will work as the "Think Tank" and provide proactive inputs and support for the development of the "Other Natural Fibre Sector" as a whole.



State Level

- 6.4.30. The anchorage at the state level will be provided by the state government concerned by establishment of Nodal Agency for the facilitation of the Natural Fibres Development. The function would be to link and implement the activities at state level in coordination with other departments, NGO, Van Panchayats, JFM, Cooperatives and private companies.

Long term strategy

- 6.4.31. The above mentioned approach "Focus Fibre Focus State" will be adopted for the 5 fibres under the first phase of the policy intervention; however, a more sustained and inclusive intervention is required in long term. So that a wider geographic area can be covered and more benefits be derived from the commercial exploitation of natural fibres in the country.
- 6.4.32. For this, sub-group proposes a 'National Other Natural Fibres Mission' to replicate best practices on pan India basis based on the census data and the findings / lessons gained from the intermediate strategy. Therefore, sub-group proposes a detailed study to evolve the objectives, structure, focus, functioning and funding for a long term 'National Other Natural Fibres Mission' in concurrence with the intermediate strategy.

Prospects/potential for the identified five fibres

- 6.4.33. The prospects of the below mentioned 5 natural fibres are based on the information gathered from different sources such as FAO statistics, Government of India – department web sites, National Banana Research Center (NBRC), Uttarakhand Bamboo and Fibre Development Board (UBFDB), internet sources, scientific studies, Philippines Farmers Bulletin, scientific papers and presentation published and from articles of news paper.



Exhibit 6.4.4:				
Fibres	Present production potential	Current Trade	Economic Potential	Achievement in 5 Years time (Per Year)
Banana	2.2 million tonnes ²⁹	US\$ 0.2 million ³⁰	Rs 112,346.7 million	Rs 1123.5 million (1% Realization)
Pineapple	0.16 million tonnes (80,000 hectares * 2 tonnes/ha ³¹)	Negligible Pine apple fibre is generally mixed with silk. It is assumed that adulteration is done at 1/3 rd price of Indian raw silk prices in the country. (Indian raw silk prices ³² during week ending December 18, 2009 - Rs 1,750 per kg) Adulteration price of pineapple fibre is Rs 583 per kg.	Rs 93,280 Million	Rs 933 Million (1% Realization)
Agave/ Sisal	20,000 tonnes ³³	US\$ 9,000 ³⁴ Value addition in India (In case of Agave fibre)	Rs 8,043 Million	Rs 160 million (2% Realization)
Hemp/ Nettle ³⁵	5,000 hectares acreage 1 hectare realization: Rs 4.80 Lakh (export value of fabric) Project undertaken in 7 districts of Uttarakhand by UBFDB in 2008	Negligible	Rs 2,400 million	Rs 240 million (10% Realization)
Flax	4,36,800 hectares ³⁶ acreage under Lin seed production. 43,680 hectares for flax and Lin seed Variety (For fibre-10% of total acreage)	303 ³⁷ tonnes is exported at US\$ 0.41 ³⁸ million in 2007 Yield ³⁹ – 1 – 1.5 metric tonnes per hectare 54,600 metric tonnes	Rs 3,301 million	Rs 330 million (10 % Realization)
		Total Returns per Year (INR Rs)		2,786.5 Million per annum

²⁹ National Research Centre for Banana (NRCB), Trichy

³⁰ NRCB, Trichy, Tamil Nadu Agricultural University (TNAU), Coimbatore

³¹ ICAR, India, Alkan state university, Philippines

³² Central Silk Board

³³ NABARD

³⁴ UBFDB

³⁵ UBFDB

³⁶ UBFDB

³⁷ FAO

³⁸ FAO

³⁹ Agropedia



COMPOSITION OF THE SUB GROUP ON OTHER NATURAL FIBRES

S. No	Name	Designation
1.	Shri Sanjay Agarwal, Office of the Dev. Commissioner [Handicrafts], New Delhi	Convener
2.	Smt Neelam Chibbar, M/s Industree Craft Foundation, Bangalore	Co-Convener
3.	Smt Alka Nangia Arora, Office of the Dev. Commissioner [Handicrafts], New Delhi	Member
4.	Father Johnson, M/s KIDS, Kottapuram	Member
5.	Smt Shama Pawar, M/s Kiskindha Trust, Karnataka	Member
6.	Smt Gulshan Nanda, M/s CCIC, New Delhi	Member
7.	Smt Manju Nirula, M/s Craft Council of India, Delhi Chapter	Member
8.	Smt Usha Krishna, M/s Word Craft Council, Chennai	Member
9.	Shri Rakesh Kumar, M/s Export Promotion Council for Handicrafts, New Delhi	Member
10.	Shri K.S. Yadav, M/s Rajiv Gandhi Charitable Trust, Rae Bareli	Member
11.	Shri Jagdish Borah, M/s NEHHDC, Guwahati	Member
12.	Shri V.S. Vijayaraghavan, Coir Board, Kochi [Kerela]	Member
13.	Shri S.T.S. Lepcha, M/s Uttranchal Bamboo & Fibre Board, Dehradun	Member
14.	Smt Anuradha Sahu, M/s Auro Arts Society, Raipur	Member
15.	Shri S. RamaKrishnan, M/s Vibrant nature, Chennai	Member
16.	Shri Manish Kumar Gupta, Ministry of Textiles, Govt. of India	Member



MINISTRY OF TEXTILES
GOVERNMENT OF INDIA
